

Installation instructions

i Refer to installation use and maintenance manual for more information.
Available user manual at link <http://www.everelettronica.it/manhw.html>



BLDC motor with integrated driver technical data



- DC power supply: 24Vdc (NEMA17) and 36Vdc (NEMA23)
- Rated torque: up to 0.44Nm at 4000rpm (see table)
- Motor power: up to 184W (see table)
- Protections against: over current, over/under voltage, overheating, short circuit between motor phase-to-phase and phase-to-ground
- Feedback: Hall effects or Magnetic Incremental and Absolute Singleturn Encoder
- Modbus or Canbus communication interfaces (not isolated)
- Service SCI interface for programming and real time debugging
- 3 digital inputs (not isolated)
- 2 digital outputs (not isolated)
- 1 analog inputs (not isolated)
- Dimensions: depend on motor power (see table)
- Protection degree: IP20
- Pollution degree: 2
- Category C3 following standard EN 61800-3
- Working temperature 5°C + 40°C; Storage temperature -25°C + 55°C
- Humidity: 5% + 85% not condensing

Platino

BLDC - SERVO - DRIVES

CANopen

Modbus

Mechanical data and models

i Handle systems with care by taking them from the motor side and not from the electronics side.

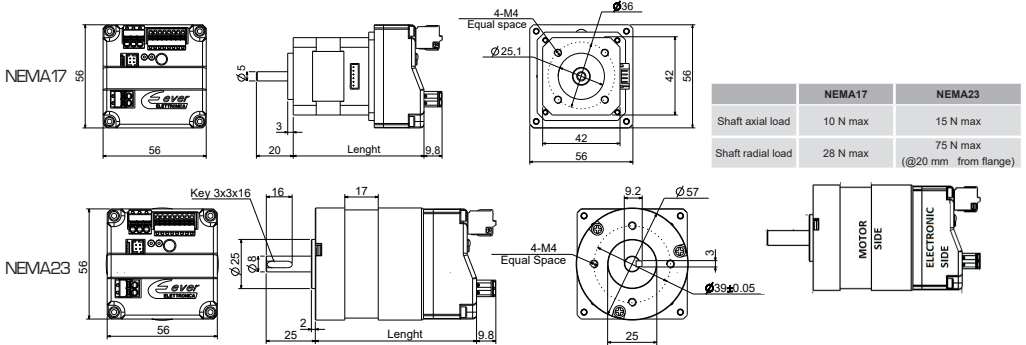

	NEMA17	NEMA23
Shaft axial load	10 N max	15 N max
Shaft radial load	28 N max	75 N max (@20 mm from flange)

System part number	Rated Torque (Nm)	Peak Torque (Nm)	Power (Watt)	Length (mm)	Motor size	Feedback Type
DM4D1026x2R1BS0	0.063	0.190	26	71	NEMA17	Hall effects
DM4D1052x2R1CS0	0.125	0.380	52	91		
DM4D1078x2R1DS0	0.185	0.530	78	111		
DM4D1104x2R1ES0	0.250	0.500	104	130	NEMA23	
DM4D1046x2R5BS0	0.110	0.330	46	82		
DM4D1092x2R5CS0	0.220	0.660	92	102		
DM4D1134x2R5DS0	0.330	0.880	134	122	NEMA17	
DM4D1184x2R5ES0	0.440	0.880	184	142		
DM4D1026x2R1GM0	0.063	0.190	26	71		
DM4D1052x2R1HM0	0.125	0.380	52	91	NEMA17	Magnetic incremental encoder or singleturn absolute encoder
DM4D1078x2R1IM0	0.185	0.530	78	111		
DM4D1104x2R1LM0	0.250	0.500	104	130		
DM4D1046x2R5GM0	0.110	0.330	46	82	NEMA23	
DM4D1092x2R5HM0	0.220	0.660	92	102		
DM4D1134x2R5IM0	0.330	0.880	134	122		
DM4D1184x2R5LM0	0.440	0.880	184	142		

x = M (Modbus) or C (Canbus)

Software configurations

Software configuration code	Description
d0380	Canopen DS402 (Canbus version)
d0390	Programmable (Canbus version)
d0490	Programmable (Modbus version)
d0390-S600	Pre-programmed Plug&Play (Canbus version)
d0490-S600	Pre-programmed Plug&Play (Modbus version)

Connections

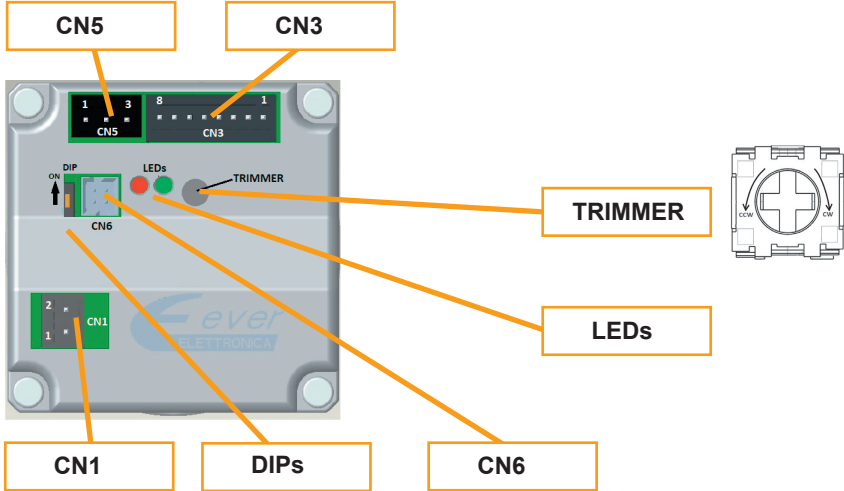

CN1: DC Supply

2 position, pitch 3.81mm, PCB header connector

CN1.1	PGND	PWR_IN	Negative DC supply input
CN1.2	VIN	PWR_IN	Positive DC power supply input

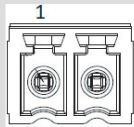

CN3: Inputs and Outputs

6 positions, pitch 5.08mm, PCB header connector

			Other software configurations	Only for S600 software configuration
CN3.1	AGND	PWR_OUT	Output negative reference for potentiometer or analog input	
CN3.2	IN_AN0	AN_IN	Analog input 0	Voltage/speed reference
CN3.3	V_POT	PWR_OUT	Voltage supply output for potentiometer	
CN3.4	B0_OUT1	DIG_OUT	Digital output OUT1	Output speed reference 24 pulses/turn
CN3.5	B0_OUT0	DIG_OUT	Digital output OUT0	Fault output
CN3.6	B0_IN3	DIG_IN		Digital input IN3
CN3.7	B0_IN2	DIG_IN	Digital input IN2	Rotation direction (High=CW)
CN3.8	B0_IN1	DIG_IN		Digital input IN1

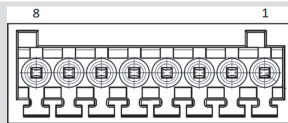

Connections

i CN5 connector is not present in "N" versions (without fieldbus)

CN5: Canbus interface ("C" version)

3 position, pitch 3.5mm, PCB header connector

CN5.1	CAN_H	DIGITAL I/O	Bus Line Dominant HIGH
CN5.2	CAN_L	DIGITAL I/O	Bus Line Dominant LOW
CN5.3	GND	PWR_OUT	Signal ground

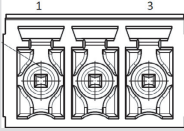

CN5: Modbus interface ("M" version)

3 position, pitch 3.5mm, PCB header connector

CN5.1	DATA+	DIGITAL I/O	Positive RS485 signal
CN5.2	DATA-	DIGITAL I/O	Negative RS485 signal
CN5.3	GND	PWR_OUT	Signal ground

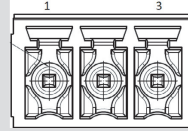

CN6: Service SCI interface

4 positions, pitch 2mm double row, PCB header connector

CN6.1	TX/RX	Transmit / Receive Line	
CN6.2	DE/RE	Drive Enable Negated / Receive Enable	
CN6.3	+5V	+5V power out	
CN6.4	GND	DNG power out	

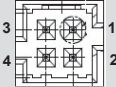

This connection is only possible with hardware and software provided by Ever.

DIP: Termination Resistor on Canbus/Modbus

4 positions, pitch 2mm double row, PCB header connector

ON	120 ohm resistor INSERTED
OFF	120 ohm resistor NOT inserted



Service SCI connection



*This connection is only possible with hardware and software provided by Ever.
Kit code: DM4_SERV00-SL or DM4D1_SERV00-EE.*

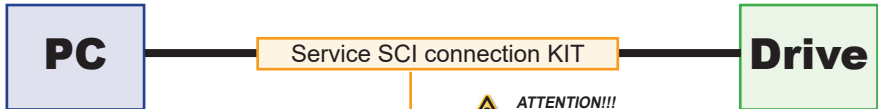

ATTENTION!!!
Correct insertion direction of the CN6: TAB LEFT.

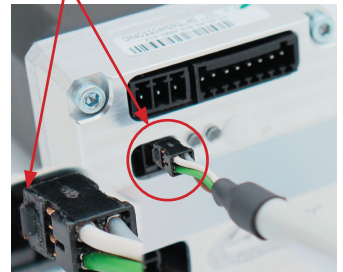
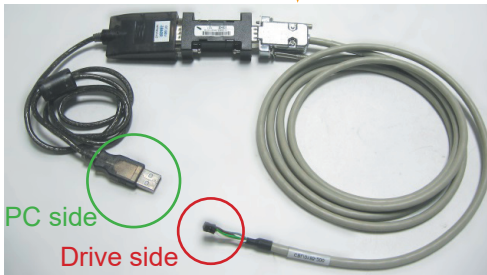

Working Status (Led)

Visualization status		Description	
1	●	Green ON	Power ON
2	● or ○	Red ON or Blinking	Error condition (see software manual for details)

S600 - Software configuration

Pre-programmed functionality of the system (Plug&Play)

Connect CN1 DC Supply and CN3 inputs/outputs

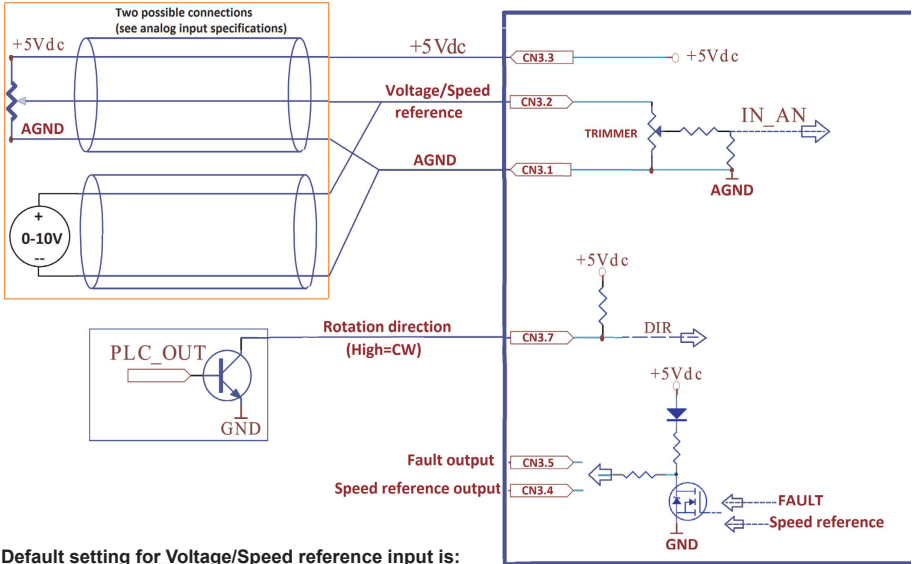

N.B.: Default setting for Voltage/Speed reference input is:

- with 5V the speed reference is 2000 rpm
- with 10V the speed reference is 4000 rpm

With the Trimmer it could be possible to change the speed reference of the motor (see Max Speed Setting paragraph).

Digital inputs connection

- i** 5-24 Vdc single-ended NPN (TTL/CMOS compatible) digital inputs (not isolated).

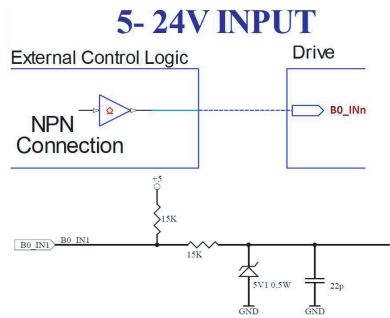

Digital outputs connection

- i** Digital outputs Open-Drain digital outputs (not isolated).

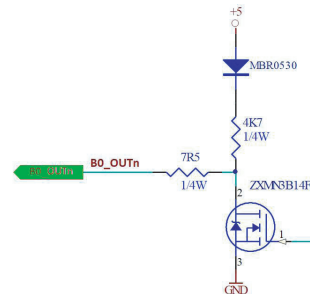

Analog input connection



Rotate the trimmer all in CW direction in order to use correctly the analog input.

0 - 10V connection

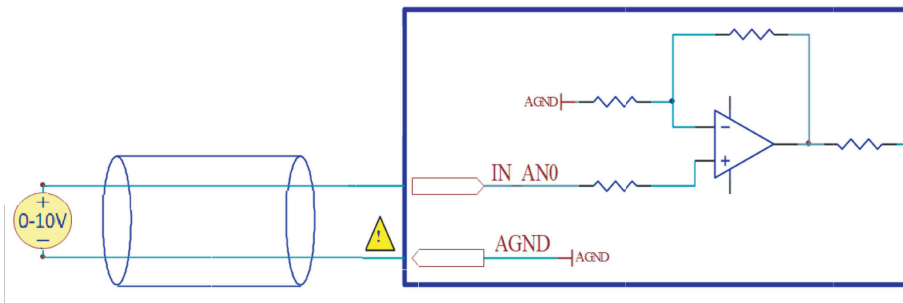

Potentiometer connection

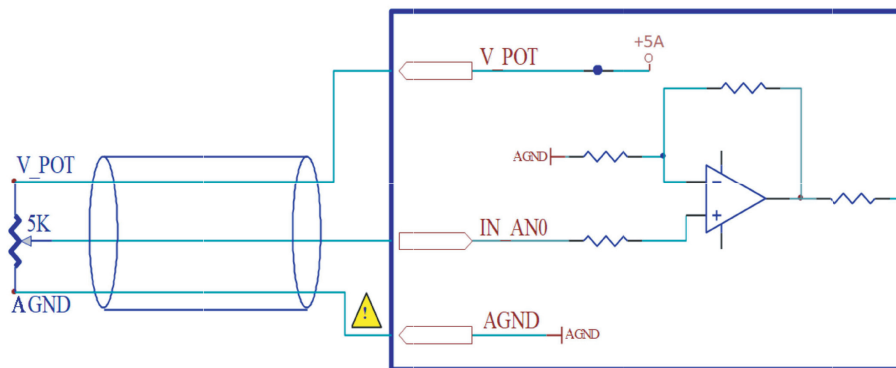

AGND is internally in common with power ground, this is potentially dangerous. Take all necessary measures to avoid possible contacts in the final installation.

Max speed setting

Through software configuration is possible to control the motor in velocity mode with analog input. With the Trimmer it could be possible to change the maximum speed of the drive. The factory value is 4000 rpm (with 10V input). To change the maximum speed setting remove the caps and rotate carefully CCW (reduce max speed) or CW (increase max speed) the Trimmer with a small screwdriver.

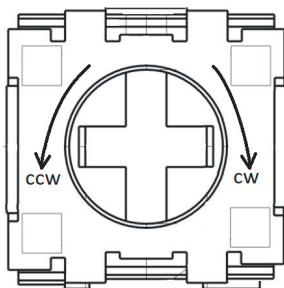

Rotate to software manual for the configuration of this feature.

Mating connectors

Connector	Description
CN1	Phoenix 1800269
CN3	Phoenix 1908101
CN5	Phoenix 1800270

Cables section

Function	Cable	
	Minimum	Maximum
Supply	0.5 mm ² (AWG20)	1.0 mm ² (AWG16)
Inputs and Outputs	0.14 mm ² (AWG26)	0.5 mm ² (AWG20)
Communication interfaces	0.25 mm ² CANbus CiA-CANOpen	---

Verify the installation

- Check all connections: power supply and inputs/outputs.
- Make sure that all settings right for the application.
- Make sure the power supply is suitable for the system.
- If possible, remove the load from the motor shaft to avoid that wrong movements cause damages.
- Enable the current to the motor and verify the applied torque.
- Enable a movement at very low speed and verify if the rotation direction is the desired one.
- Disconnect the power supply, connect the load on the motor and check the full functionality.

Drive's fault analysis



When any of the following situations occur, the drive is placed in a fault condition.

DEFECT	CAUSE	ACTION
Intervention of the thermal protection.	Can be caused by a heavy working cycle or a high current in the motor.	Improve the drive cooling by a natural or fan air flow. Consider to use a motor with a higher torque vs current rating.
Intervention of the current protection.	Short circuit on the motor powering stage(s) of the drive.	Contact Ever Elettronica.
Intervention of the over/under voltage protection.	Supply voltage out of range.	Check the value for the supply voltage.
Open phase motor protection.	Motor windings to drive not proper connection.	Contact Ever Elettronica.



When any of the following situations occur, the drive doesn't work and isn't placed in an error condition.

DEFECT	CAUSE	ACTION
Noisy motor movement with vibrations.	Can be caused by a lack of power supply to a phase of the motor or a poor regulation of the winding currents.	Change the motor speed to avoid a resonance region.
The external fuse on the power supply of the drive is burned.	Can be caused by a wrong connection of the power supply.	Connect the power supply correctly and replace the fuse.
At high speed, the motor torque is not enough.	Can be due to a 'self-limitation' of motor current and torque.	Increase the motor current or increase the supply voltage (always within the limits of the motor).

EVER Elettronica

Via del Commercio, 2/4 - 9/11

Loc. San Grato Z. I

26900 - L O D I - Italy

Phone +39 0371 412318 - Fax +39 0371 412367

email: infoever@everelettronica.it

web: www.everelettronica.it

