

Installation instructions

For more information about drive installation, use and maintenance



2 phase step motor bipolar chopper drive technical data

- AC power supply: 100 ± 240 Vac (monophase)
- Phase current: up to 4,2 Apeak
- Chopper frequency: ultrasonic 40KHz
- Emulated Step angle: Full Step, 1/2, 1/4, 1/8, 1/2.5, 1/5, 1/10 configurable by means of Dip-Switches and other step angle could be defined by software
- Protections against: over current, over/under voltage, overheating, short circuit between motor phase-to-phase and phase-to-ground
- Service SCI interface for programming and real time debugging
- Dimensions: 152 x 130 x 46 mm (without connectors)
- Protection degree: IP20
- Pollution degree: 2
- Working temperature: 5°C ± 40°C
- Storage temperature: -25°C ± 55°C
- Humidity: 5% ± 85% not condensing

TITANIO
VECTOR - STEPPER - DRIVES

Connections and mechanical drawing

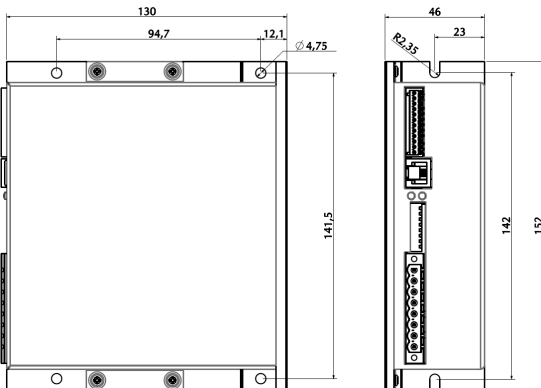
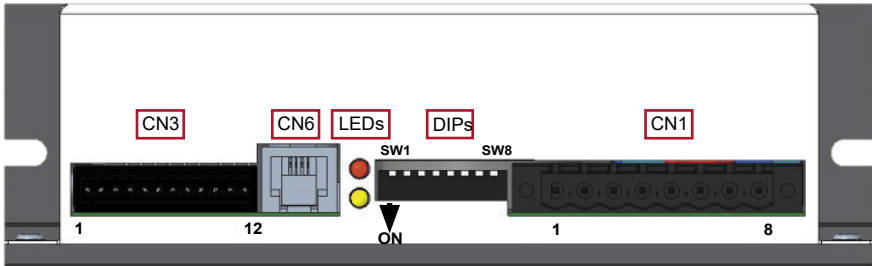

CN1: Power supply and Motor 8 position, pitch 5.08mm, PCB header connector

CN1.1	B/	PWR_OUT	Motor output phase B/
CN1.2	B	PWR_OUT	Motor output phase B
CN1.3	A	PWR_OUT	Motor output phase A
CN1.4	A/	PWR_OUT	Motor output phase A/
CN1.5	PE	---	Motor shield
CN1.6	PE	---	Earth ground
CN1.7	ACin	PWR_IN	AC supply input
CN1.8	ACin	PWR_IN	AC supply input

CN3: Digital inputs and output 12 position, pitch 2.5mm, PCB header connector

CN3.1	FAULT+	DIG_OUT	Fault output positive side
CN3.2	FAULT-	DIG_OUT	Fault output negative side
CN3.3	Step +	DIG_IN	Clock frequency + input (Clock_up +)
CN3.4	Step -	DIG_IN	Clock frequency - input (Clock_up -)
CN3.5	Dir +	DIG_IN	Motor direction + input (Clock_down +)
CN3.6	Dir -	DIG_IN	Motor direction - input (Clock_down -)
CN3.7	EN +	DIG_IN	Enable + input
CN3.8	EN -	DIG_IN	Enable - input
CN3.9	Boost +	DIG_IN	Boost + input
CN3.10	Boost -	DIG_IN	Boost - input
CN3.11	N.C.	---	Not connected
CN3.12	N.C.	---	Not connected

CN6: Service SCI Interface RJ11 6P4C, PCB header connector

CN6.1	TX / RX	Transmit / Receive line
CN6.2	DE / RE	Drive enable negated / Receive enable
CN6.3	+ 5 V	+ 5 V power out
CN6.4	GND	GND power out



This connection is **only** possible with hardware and software provided by Ever.

Service SCI connection



This connection is **only** possible with hardware and software provided by Ever.
Kit code: LW3A9_SERV00-SL

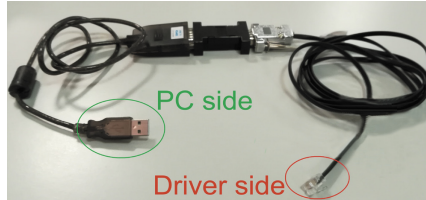

Dip-Switches Settings

Motor Phase Current (Apeak)	DIPs		Default
	SW1	SW2	
2.80	off	off	X
3.40	on	off	
4.00	off	on	
4.20	on	on	

Step angle	DIPs			Default
	SW3	SW4	SW5	
Reserved	off	off	off	
1/2	on	off	off	
1/4	off	on	off	
1/8	on	on	off	
1/2.5	off	off	on	
1/5	on	off	on	X
1/10	off	on	on	
SW Defined	on	on	on	

DIP SW6	Drive enable polarity	Default
off	Enable Asserted = Drive Disable	X
on	Enable Asserted = Drive Enable	

DIP SW7	Drive Control Mode	Default
off	Step and Dir. mode	X
on	Clock_up / Clock_down mode	

DIP SW8	Reserved	Default
off	Reserved	X
on	Reserved	

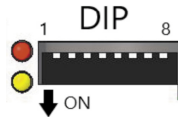

NOTE: the device reads the Dip-Switches only at powering up.
If it's necessary a setting change, shut down the system, change the settings and start the up the system again to make the changes operating.

Working status (LEDs)

Driver disabled: green blinking (1s)

Driver enabled: green on

Motor open phase: red on

Motor phase shortcut: red blinking (200 ms)

Over voltage: red on (2 sec) – yellow on (1 sec)

Under Voltage: red on (2 sec) – yellow on (1 sec) – yellow on (1 sec)

Motor stall: yellow blinking (200 ms)

Over temperature: red on (2 sec) – yellow on (1 sec) – yellow on (1 sec) – yellow on (1 sec)

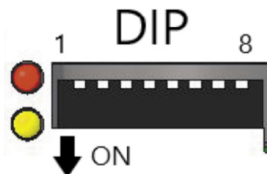

Connection to the digital inputs



Differential PNP, NPN and Line Driver type.

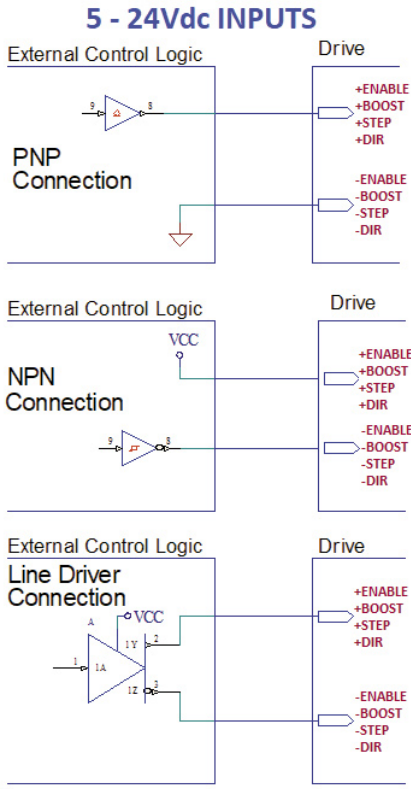

Standard (EN & BOOST)			
Characteristics	MIN.	MAX.	Unit
Supply Voltage	5	24	Vdc
Inputs Frequency	---	10	kHz
Threshold switching voltage	1.9	2.4	Vdc
Current at 5Vdc	---	6.28	mA
Current at 24 Vdc	---	8.75	mA

High speed (STEP & DIR)			
Characteristics	MIN.	MAX.	Unit
Supply Voltage	5	24	Vdc
Inputs Frequency	---	250	kHz
Threshold switching voltage	1.9	2.4	Vdc
Current at 5Vdc	---	7.52	mA
Current at 24 Vdc	---	10	mA

Connection to the digital output



24 Vdc - PNP/NPN photo relay output (optoisolated) - $I_{outMAX} = 400\text{ mA}$ - $F_{MAX} = 250\text{ Hz}$

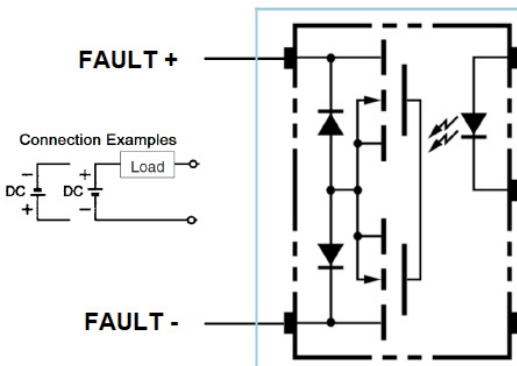

Mating connectors

Connector	Description
CN1	Phoenix 1763753
CN3	Phoenix 1755279

Cables section

Function	Cable	
	Minimum	Maximum
Power supply and PE	0.5 mm ² (AWG20)	2.5 mm ² (AWG12)
Motor output	0.5 mm ² (AWG20)	2.5 mm ² (AWG12)
Digital inputs	0.08 mm ² (AWG28)	0.5 mm ² (AWG20)
Digital output	0.08 mm ² (AWG28)	0.5 mm ² (AWG20)

Verify the installation

- Check all connections: Power supply, Stepper motor and control logics.
- Make sure that all settings are correct for the application.
- Make sure that the characteristics of the DC power supply are appropriate for the drive.
- If possible, remove the load from the rotor of the motor to avoid wrong movements and eventual damages.
- Supply power and make sure that the green led is on or blinking. If the led is OFF, shut down immediately and check if all connections are correct.
- Enable the current in the motor (without STEP Clock) and, if possible, verify the presence of the Holding Torque.
- Execute a movement of some steps and verify if the rotation direction is the desired one.

i *If the motion direction is not the desired one, it is possible to change it leaving the DIR input unchanged and reversing the connection of a single phase of the motor to CN1, for example A with A'.*

- Disconnect the power supply, fix the motor to the load and check the full functionality.

Analysis of malfunctions

When any of the following situations occur, the drive is placed in a fault condition.

	DEFECT	CAUSE	ACTION
	Intervention of the thermal protection.	Can be caused due to a heavy working cycle or a high current in the motor.	Improve the drive cooling by a decent air flow or a fan. Consider to use a motor with a higher torque vs. current rating.
	Intervention of the current protection.	Short circuit to the motor output stage(s) of the drive.	Check motor windings and cables and remove the short circuits replacing the faulty cables or the motor if necessary.
	Intervention of the over/under voltage protection.	Supply voltage out of range.	Check the value of the supply voltage.
	Open phase motor protection.	Open circuit from motor windings and drive.	Check motor cables and connections to the drive.

At any of the following situations occur, the drive doesn't work and isn't placed in an error condition.

	DEFECT	CAUSE	ACTION
	Noisy motor movement with vibrations.	Can be caused due to a lack of power supply to a phase of the motor, a poor regulation of the winding currents.	Check the cables and connections of the motor and/or change the motor speed to exit a resonance region.
	The external fuse on the power supply of the drive is burned	Can be caused by a wrong connection of the power supply.	Connect the power supply correctly and replace the fuse.
	At high speed, the motor torque is not enough.	It can be due to a motor current self-limitation.	Increase the motor current (always within the limits), increase the supply voltage, change motor connection from series to parallel.

Ever Motion Solutions

Via del Commercio, 2/4 - 9/11

Loc. San Grato Z. I

26900 - L O D I - Italy

Phone +39 0371 412318 - Fax +39 0371 412367

email: infoever@everelettronica.it

web: www.everelettronica.it

