

Installation instructions

i Refer to installation use and maintenance manual for more information.

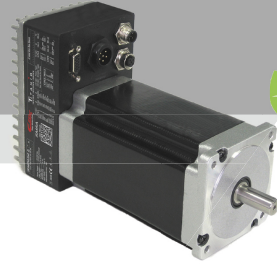

Bipolar drive integrated with 2 phase step motor

- AC power Supply: 18 ÷ 100Vac
- DC Logic Supply: 24Vdc (mandatory and isolated)
- Phase current: up to 8.5 Arms (12 Apk)
- Chopper frequency: ultrasonic 40 kHz
- Stepless Control Technology (65536 position per turn)
- Protections: over-current, over-temperature, short circuit phase-phase motor and phase-ground
- Modbus or Canbus communication interfaces
- Digital inputs (opto-coupled)
- Digital outputs (opto-coupled and supplied from 24Vdc logic supply)
- Analog input (not isolated)
- Dimensions: Length (mm)x135x86mm
- Connectors not included(refer to picture)
- IP protection: IP65
- Working temperature 5°C + 40°C, storage temperature -25°C + 55°C
- Humidity: 5% + 85% not condensing

Mechanical data

Handle systems with care by taking them from the motor side and not from the electronics side.

Shaft axial load = 60 N max
Shaft radial load = 220 N max (on front shaft end)

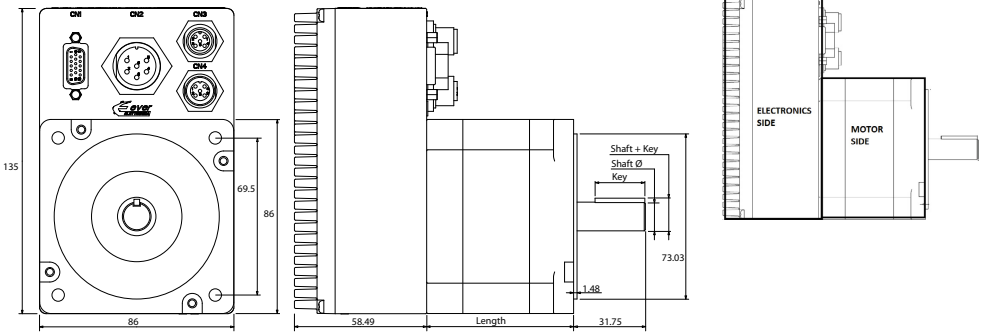

Composition code	SM5A	4	85P	x	0	y	3	z	w	0
------------------	-------------	----------	------------	----------	----------	----------	----------	----------	----------	----------

Model (z letter)	Length (mm)	Shaft Ø (mm)	Key on shaft (mm)	Holding Torque (Nm)	Rotor Inertia (g.cm ²)
SM5A485P_A	67.5	9.53	3.0 x 3.0 x 22.0	4.0	1300
SM5A485P_B	78.5	12.7	3.175 x 3.175 x 22.23	5.0	1900
SM5A485P_C	96.5	12.7	3.175 x 3.175 x 22.23	7.0	2700
SM5A485P_D	118.5	12.7	3.175 x 3.175 x 22.23	8.5	3800
SM5A485P_E	159.5	15.87	4.763 x 4.763 x 22.23	12.5	5700

Model (w letter)	Encoder type
SM5A485P_N	Without feedback
SM5A485P_7	Incremental encoder 4096ppr
SM5A485P_M	Incremental encoder 4096ppr + Absolute single turn
SM5A485P_B	Absolute multiturn encoder Biss-C

System connections

Connectors:

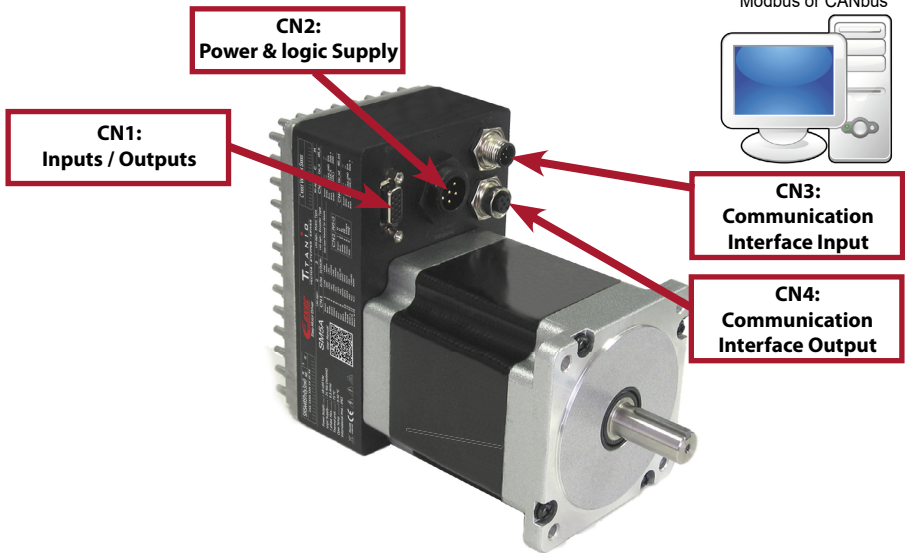

Composition code	SM5A	4	85P	x	0	y	3	z	w	0
------------------	------	---	-----	---	---	---	---	---	---	---

CN1: Digital inputs and outputs

y = 2 : 4 digital inputs (differential) and 3 digital outputs			
CN1.1	+B0_IN0	DIG_IN	Digital input positive side B0_IN0
CN1.2	-B0_IN0	DIG_IN	Digital input negative side B0_IN0
CN1.3	+B0_IN1	DIG_IN	Digital input positive side B0_IN1
CN1.4	-B0_IN1	DIG_IN	Digital input negative side B0_IN1
CN1.5	+B0_IN2	DIG_IN	Digital input positive side B0_IN2
CN1.6	-B0_IN2	DIG_IN	Digital input negative side B0_IN2
CN1.7	+B0_IN3	DIG_IN	Digital input positive side B0_IN3
CN1.8	-B0_IN3	DIG_IN	Digital input negative side B0_IN3
CN1.9	B0_OUT0	DIG_OUT	PNP digital output OUT0
CN1.10	B0_OUT1	DIG_OUT	PNP digital output OUT1
CN1.11	B0_OUT2	DIG_OUT	PNP digital output OUT2
CN1.12	VSS	PWR_IN	Negative reference for digital outputs
CN1.13	n.c.	n.c.	Not connected
CN1.14	n.c.	n.c.	Not connected
CN1.15	n.c.	n.c.	Not connected
y = 3 : 4 digital inputs (single-ended), 3 digital outputs and 2 analog inputs			
CN1.1	+B0_IN0	DIG_IN	Digital input positive side B0_IN0
CN1.2	-IN_AN1	AN_IN	Negative side analog input IN_AN_1
CN1.3	+B0_IN1	DIG_IN	Digital input positive side B0_IN1
CN1.4	+IN_AN1	AN_IN	Positive side analog input IN_AN1
CN1.5	+B0_IN2	DIG_IN	Digital input positive side B0_IN2
CN1.6	-IN_AN0	AN_IN	Negative side analog input IN_AN_0
CN1.7	+B0_IN3	DIG_IN	Digital input positive side B0_IN3
CN1.8	B0_COM_IN	DIG_IN	Reference common inputs
CN1.9	B0_OUT0	DIG_OUT	PNP digital output OUT0
CN1.10	B0_OUT1	DIG_OUT	PNP digital output OUT1
CN1.11	B0_OUT2	DIG_OUT	PNP digital output OUT2
CN1.12	VSS	PWR_IN	Negative reference for digital outputs
CN1.13	+IN_AN0	AN_IN	Positive side analog input IN_AN_0
CN1.14	AGND	PWR_OUT	Output negative reference for potentiometers
CN1.15	VPOT	PWR_OUT	Output positive supply for potentiometers

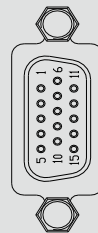

Connector Type: SubD 15 pins, Female, High Density, IP68
 Manufacturer: LTW
 Model: LTWHDB-15PFFS-SL8001

System connections

CN2: Power & Logic Supply

CN2.1	ACin	PWR_IN	AC input power supply 18 + 100 Vac
CN2.2	ACin	PWR_IN	AC input power supply 18 + 100 Vac
CN2.3	ACin	PWR_IN	AC input power supply 18 + 100 Vac
CN2.4	PE	EARTH	Environmental Protective Earthing (PE)
CN2.5	+Vlog	PWR_IN	Positive logic supply +24 Vdc (mandatory and isolated)
CN2.6	-Vlog	PWR_IN	Reference negative logic supply GND (mandatory and isolated)

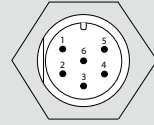

Connector Type: screw, 6 pins, male, IP67
 Manufacturer: LTW
 Model: LTWCB-06PMMS-SC7001

Composition code	SM5A	4	85P	x	0	y	3	z	w	0
------------------	------	---	-----	---	---	---	---	---	---	---

CN3 Communication interface input

x = C: CANbus			
CN3.1	n.c.	---	Not connected
CN3.2	n.c.	---	Not connected
CN3.3	CAN_GND	PWR output	Signal ground
CN3.4	CAN_H	Digital I/O	Bus Line High
CN3.5	CAN_L	Digital I/O	Bus Line Low
x = M: Modbus RS485			
CN3.1	n.c.	---	Not connected
CN3.2	n.c.	---	Not connected
CN3.3	0V_A	PWR output	Signal ground
CN3.4	Data +	Digital I/O	Not inverting signal RS485
CN3.5	Data -	Digital I/O	Inverting signal RS485

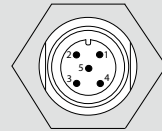

Connector Type: M12, 5 pins, male, IP68
 Manufacturer: LTW
 Model: LTW1205-05PMMS-SF8001

CN4 Communication interface output

x = C: CANbus			
CN4.1	n.c.	---	Not connected
CN4.2	n.c.	---	Not connected
CN4.3	CAN_GND	PWR output	Signal ground
CN4.4	CAN_H	Digital I/O	Bus Line High
CN4.5	CAN_L	Digital I/O	Bus Line Low
x = M: Modbus RS485			
CN4.1	n.c.	---	Not connected
CN4.2	n.c.	---	Not connected
CN4.3	0V_A	PWR output	Signal ground
CN4.4	Data +	Digital I/O	Not inverting signal RS485
CN4.5	Data -	Digital I/O	Inverting signal RS485

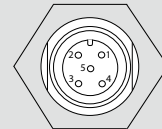

Connector Type: M12, 5 pins, female, IP68
 Manufacturer: LTW
 Model: LTW1205-05PFFS-SF8001

Analog inputs connection (only for version y=3)



The resolution of the analog input depends from the type of the connection which could be defined by software: differential or potentiometer.

Differential connection

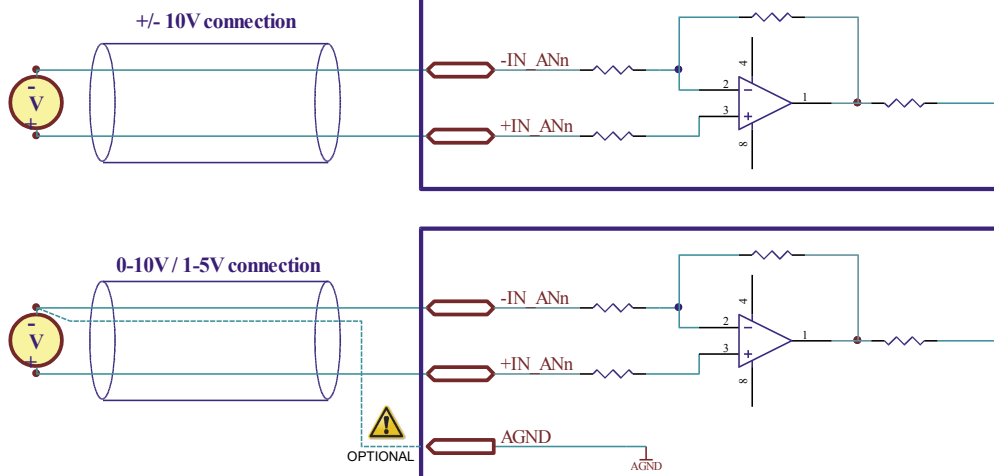

The connection from an external reference and AGND should be preceded by a thorough risk analysis on the machine/circuit in which the drive will be installed.

Potentiometer connection

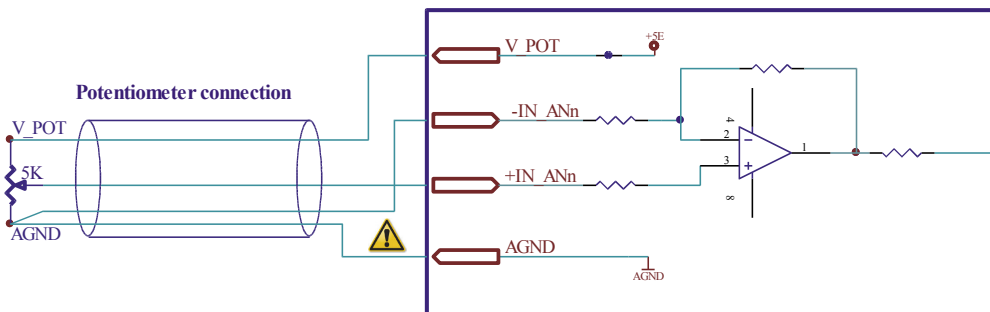

AGND is internally in common with power ground, this is potentially dangerous. Take all necessary measures to avoid possible contacts in the final installation.

Mating cable kit

Connection	Connector kit information		Kit order code
CN1	Pin: Pinout: Conductors: Cable: Waterproof rate:	15 position 1 - Brown, 2 - Blue, 3 - White, 4 - Green, 5 - Yellow, 6 - Grey, 7 - Pink, 8 - Red, 9 - Black, 10 - Orange, 11 - Purple, 12 - Light Green, 13 - Black/White, 14 - Brown/White, 15 - Red/White. UL2464 26AWG Black PVC Jacket (UV resistant) ext. Ø 6.5mm IP67	CA/LTWHDB15AF01
CN2	Pin: Pinout: Conductors: Cable: Waterproof rate:	6 position 1 - Brown, 2 - Blue, 3 - White, 4 - Green, 5 - Yellow, 6 - Grey. UL2464 20AWG Black PVC Jacket (UV resistant) ext. Ø 6.5mm IP67	CA/LTWCB06BF01
CN3	Pin: Pinout: Conductors: Cable: Waterproof rate:	5 position 1 - Brown, 2 - White, 3 - Blue, 4 - Black, 5 - Green or Gray. UL2517 22AWG Black PVC Jacket (UV resistant) ext. Ø 5.1mm IP68	CA/LTW1205BF01
CN4	Pin: Pinout: Conductors: Cable: Waterproof rate:	5 position 1 - Brown, 2 - White, 3 - Blue, 4 - Black, 5 - Green or Gray. UL2517 22AWG Black PVC Jacket (UV resistant) ext. Ø 5.1mm IP68	CA/LTW1205BM01

Section of the cables

Function	Cable	
	Minimum	Maximum
Power supply	0.5 mm ² (AWG20)	1.5 mm ² (AWG15)
Communication interface	0.25 mm ² (AWG23) CANbus CIA-CANopen	
Digital inputs	0.14 mm ² (AWG25)	0.5 mm ² (AWG20)
Digital outputs	0.14 mm ² (AWG25)	0.5 mm ² (AWG20)

Verify the installation

- Check all connection: power supply and inputs/outputs.
- Make sure all settings right for the application.
- Make sure the power supply is suitable for the drive.
- If possible, remove the load from the motor shaft to avoid that wrong movements cause damage.
- Enable the current to the motor and verify the applied torque.
- Enable a movement of some steps and verify if the rotation direction is the desired one.
- Disconnect the power supply, connect the load on the motor and check the full functionality.

Analysis of malfunctions



When one of the following situations occur, the drive doesn't function correctly and it is reported an error.

DEFECT	CAUSE	ACTION
The external fuse to the drive burns.	May be due to a wrong connection of the power supply.	Adjust the connection and recover the fuse. Use a fuse suitable for the application.
Over temperature protection.	May be due to a duty cycle.	Increase the air flux and if it is possible chose a motor with higher torque at same current value.
Over current protection.	May be due to a short circuit on the motor power stage.	Shut down the power supply and check if the motor is damaged.
Noisy motor movement with vibrations.	May be caused due to a state of resonance.	Increase the resolution of the step angle and/or change the motor velocity to avoid resonance area.
The motor produce torque but doesn't rotate.	May be caused due to a wrong connection of the I/O's.	Check the connection of the I/O's.

Ever Motion Solutions

Via del Commercio, 2/4 - 9/11
 Loc. San Grato Z. I
 26900 - L O D I - Italy
 Phone +39 0371 412318 - Fax +39 0371 412367
 email: infoever@everelettronica.it
 web: www.everelettronica.it

