

## Installation instructions



Refer to installation use and maintenance manual for more information.



## 2 phase bipolar stepper drive technical data:

- DC power supply: 12 ÷ 48 Vdc
- DC logic supply: 12-48 Vdc (optional and not isolated)
- Phase current: up to 4 Arms (5.65 Apeak)
- Chopper frequency: ultrasonic 40 kHz
- Stepless Control Technology (65536 position per turn)
- Protections against: over current, over/under voltage, overheating, short circuit between motor phase-to-phase and phase-to-ground
- EtherCAT communication interfaces
- Incremental Encoder input (not isolated): 5V Single-Ended (TTL/CMOS)
- Service SCI interface for programming and real time debugging
- 2 digital inputs (opto-coupled)
- 2 digital outputs (opto-coupled)
- Dimensions: 145 x 56 x 50 mm (without connectors)
- Protection degree: IP65
- Pollution degree: 2
- Category C3 following standard EN 61800-3
- Working temperature 5°C ÷ 40°C; Storage temperature -25°C ÷ 55°C
- Humidity: 5% ÷ 85% not condensing.

error  
less  
servo  
efficient  
**else**  
technology  
by Ever Electronics

**TITANIO**  
VECTOR - STEPPER - DRIVES

**EtherCAT**  
EtherCAT® is registered trademark and patented technology,  
licensed by Beckhoff Automation GmbH, Germany.

## Mechanical data

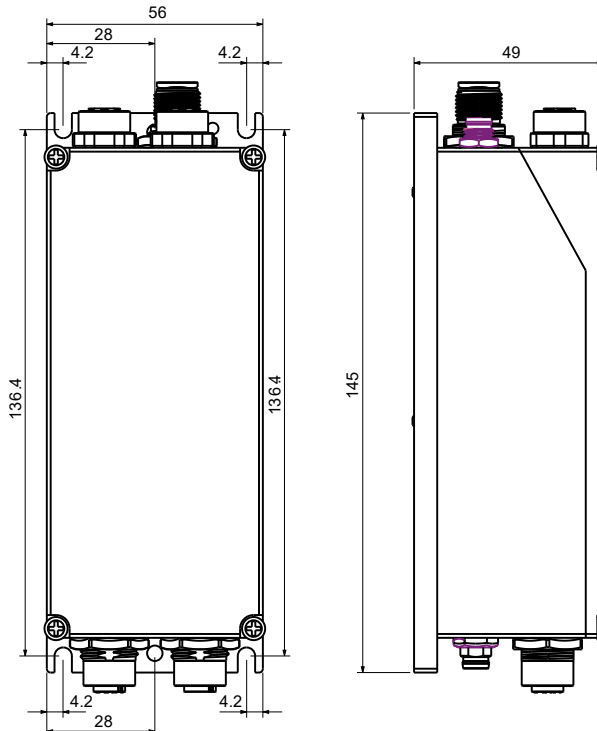

## System connections

Connectors:

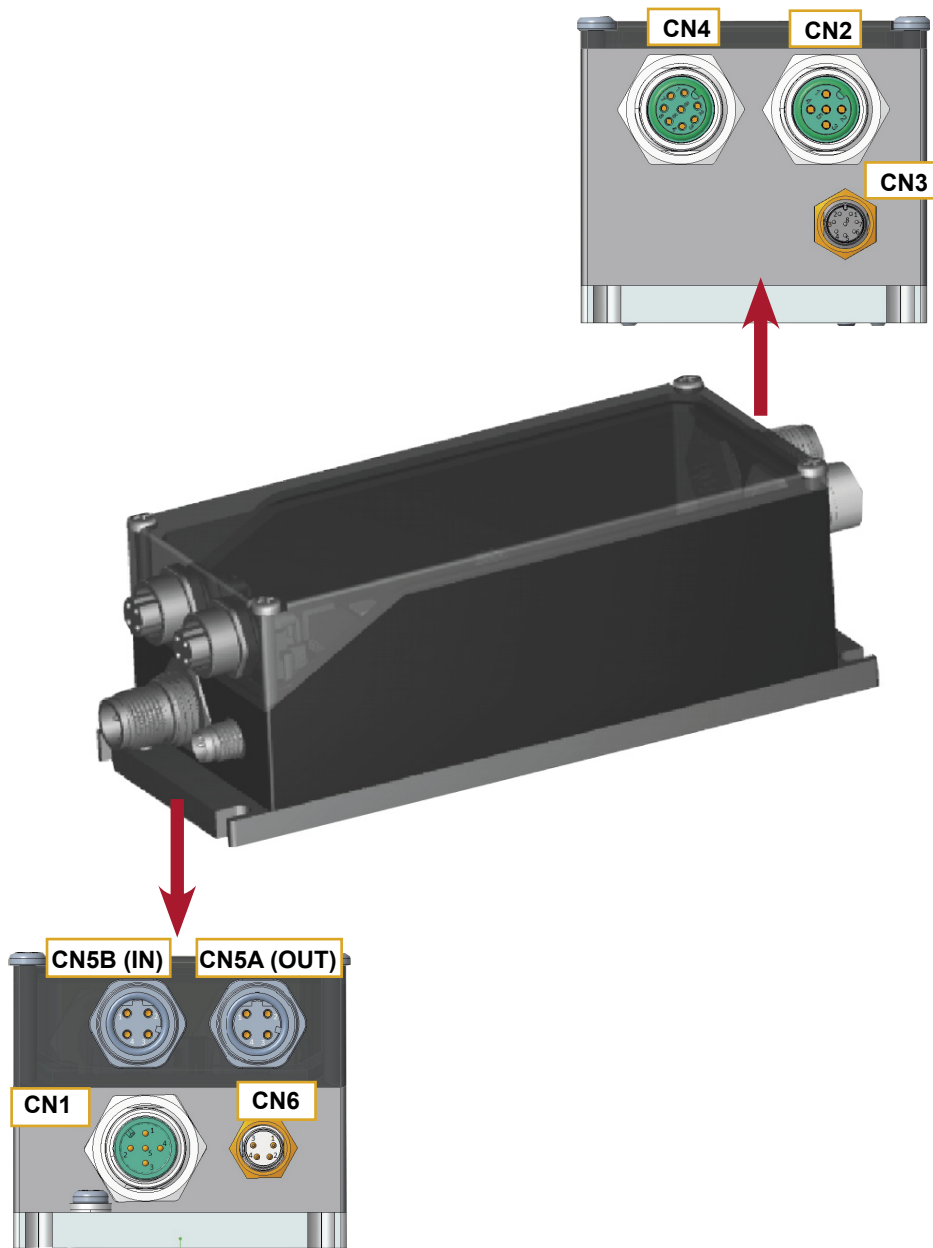

**⚠** *Power and Logic supplies are not isolated but they have common reference inside the drive.  
(GND and PGND are in common)*

# System connection

## CN1: Power supply

M12 A-Code Spin Male

CN1.1	GND	PWR_IN	Negative DC logic supply input
CN1.2	VLOG	PWR_IN	Positive DC logic supply input
CN1.3	PE	/	Protective Earth
CN1.4	PGND	PWR_IN	Negative DC power supply input
CN1.5	VIN	PWR_IN	Positive DC power supply input

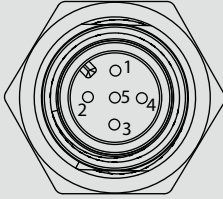

## CN2: Motor connection

M12 A-Code Spin Female

CN2.1	A	PWR_OUT	Motor output phase A
CN2.2	A/	PWR_OUT	Motor output phase A/
CN2.3	B	PWR_OUT	Motor output phase B
CN2.4	B/	PWR_OUT	Motor output phase B/
CN2.5	n.c.	Not connected	Not connected

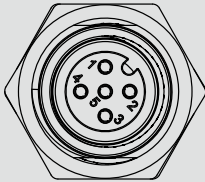

## CN3: Inputs and Outputs

M8 A-Code 8 pin Male

CN3.1	+IN2	DIG_IN-	Digital input 2 positive side
CN3.2	-IN2	DIG_IN	Digital input 2 negative side
CN3.3	+IN3	DIG_IN	Digital input 3 positive side
CN3.4	-IN3	DIG_IN	Digital input 3 negative side
CN3.5	DIG_OUT0	DIG_OUT	PNP digital output OUT0
CN3.6	DIG_OUT1	DIG_OUT	PNP digital output OUT1
CN3.7	V-OUT	PWR_IN	24 Vdc supply for digital output
CN3.8	VSS	PWR_IN	Negative input supply for digital output

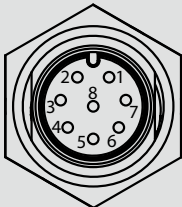

## CN4: Encoder input

M12 A-Code Spin Female

CN4.1	+5E	PWR_OUT	+5 Vdc power supply
CN4.2	GND	PWR_OUT	Negative side of supply
CN4.3	ENCA	DIG_IN	Encoder Phase A input
CN4.4	n.c.	Not connected	Not connected
CN4.5	ENCB	DIG_IN	Encoder Phase B input
CN4.6	n.c.	Not connected	Not connected
CN4.7	ENCZ	DIG_IN	Encoder Phase Z input
CN4.8	n.c.	Not connected	Not connected

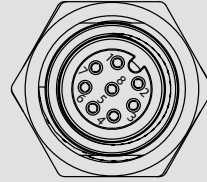

## CN5A e CN5B: EtherCAT Interface

100BASE-TX (100Mb/sec) ports

Dual M12 D-Code 4 pin Female (IN-OUT)

CN5.1	TX/RX	Transmit / Receive Line
CN5.2	DE/RE	Drive Enable Negated / Receive Enable
CN5.3	+5V	+5V power out
CN5.4	GND	DNG power out
Housing		Connected to PE

CN5B (IN)

CN5A (OUT)

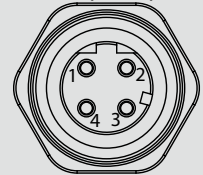
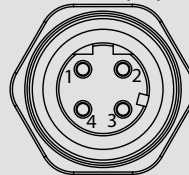

## CN6: Service SCI Interface

M8 A-Code 4 pin Male

CN6.1	GND	GND power out
CN6.2	+ 5 L	+ 5 Vpower out
CN6.3	DE / RE	Drive Enable Negated / Receive Enable
CN6.4	TX / RX	Transmit / Receive Line

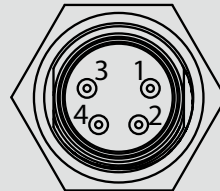

## Working Status (Led)

	Visualization status	Description
1	Green OFF	Bus status 'Init'
2	Green ON	Bus status 'Operational'
3	Green Blinking (1s)	Bus status 'Pre-Operational'
4	Green Single Flash	Bus status 'Safe-Operational'
5	Yellow Blinking Slow (0 ~ 5 Hz)	Normal functioning
6	Yellow Blinking Fast (10 Hz)	FAULT condition: check diagnostic parameters with PLC or connect with Service SCI kit and check.



*Note: Leds are visible from the upper side of the drive (serigraphy side)*

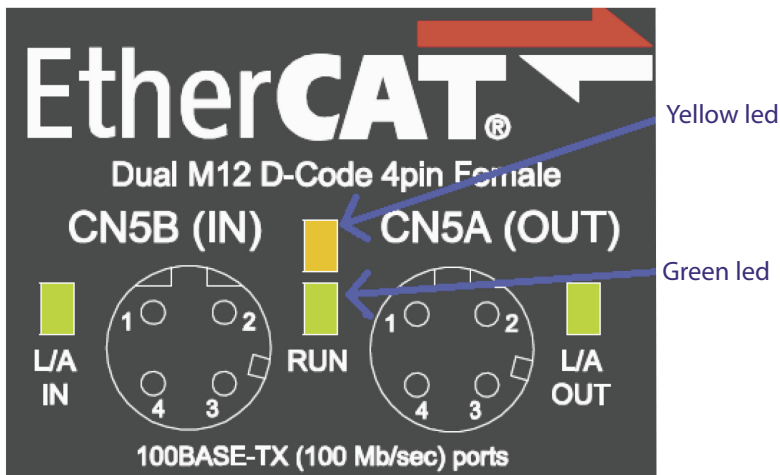

## Service SCI connection



*This connection is **only** possible with hardware and software provided by Ever.  
Kit code: SN4D\_SERV00-SL.*

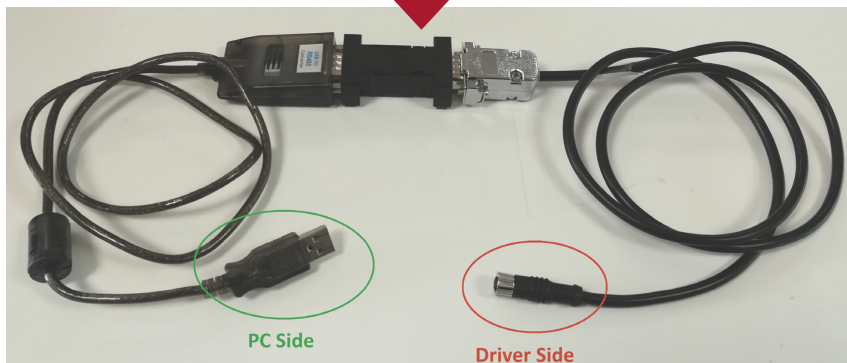

## Encoder input connection

Electrically NOT-isolated digital inputs for Single-Ended 5Vdc TTL/CMOS.  
Maximum supply current 100 mA.

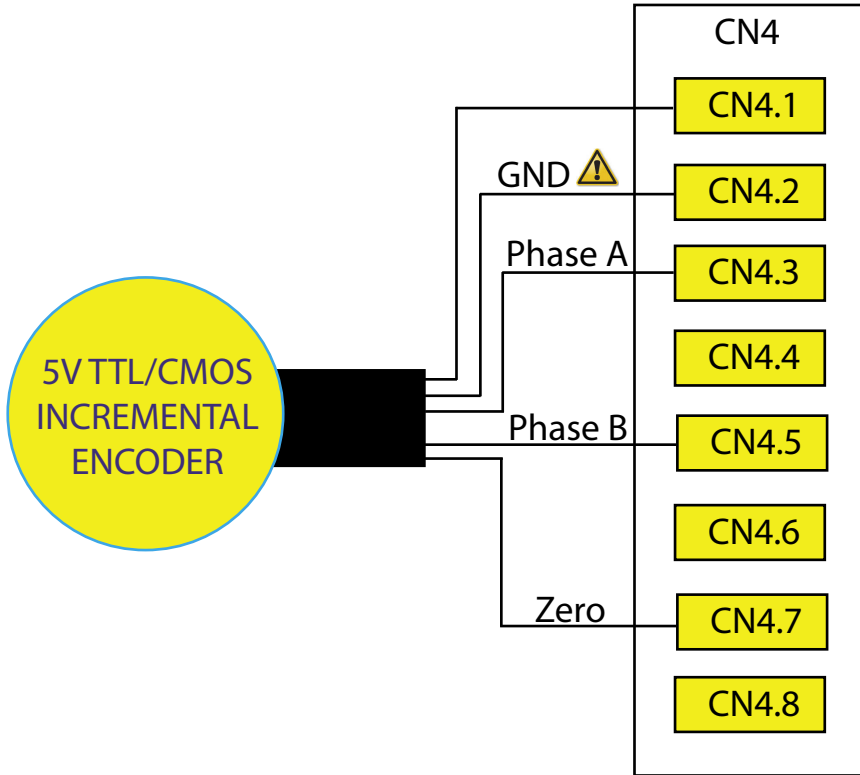

*GND is internally in common with power ground, this is potentially dangerous. Take all necessary measures to avoid possible contacts in the final installation.*

## Digital inputs connection



Differential PNP, NPN and Line Driver type.

### 3.3 - 24V INPUT

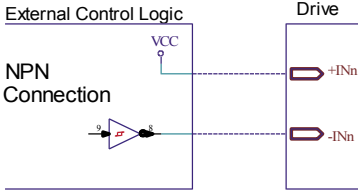
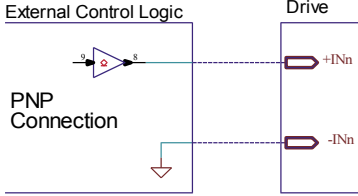

### 2 - 24V INPUT

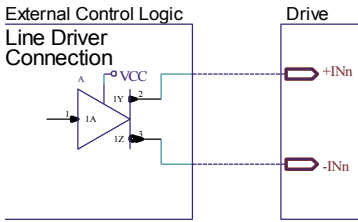

Characteristics	MIN.	MAX.	Unit
Supply voltage	2 <sup>(1)</sup>	24	Vdc
Inputs frequency	--	1	Mhz
Threshold switching voltage	1.61 <sup>(1)</sup>	--	Vdc
Current at 2 Vdc	--	2.53	mA
Current at 3.3 Vdc	--	5.84	mA
Current at 5 Vdc	--	6.28	mA
Current at 24 Vdc	--	8.75	mA

*(1) N.B.: it's recommended to use 2 Vdc digital inputs only in differential Line-Driver configuration to have more noise immunity.*

## Digital outputs connection



Digital outputs are PNP with  $V_{OUTmax} = 24$  Vdc,  $I_{OUTmax} = 100$  mA,  $F_{max} = 500$  kHz.

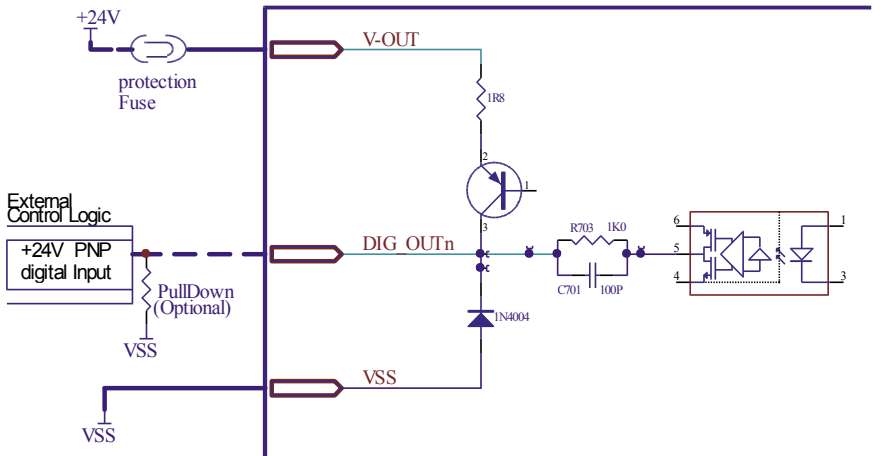

## Mating cables kit

Connector	Ever code	Description	Conductors	Cable	Waterproof	Length	Lead wires colours pinout																											
CN1	CA/LTW1205BF01	M12 A-Code 5 pin Female	UL2517 AWG#22	Black PVC Jacket	IP68	1 m	<table border="1"> <tr> <td>1</td><td>2</td><td>3</td><td>4</td><td>5</td><td></td><td></td><td></td><td></td><td></td> </tr> <tr> <td>Brown</td><td>White</td><td>Blue</td><td>Black</td><td>Grey</td><td></td><td></td><td></td><td></td><td></td> </tr> </table>								1	2	3	4	5						Brown	White	Blue	Black	Grey					
1	2	3	4	5																														
Brown	White	Blue	Black	Grey																														
CN2	CA/LTW1205BM01	M12 A-Code 5 pin Male	UL2517 AWG#22	Black PVC Jacket	IP68	1 m	<table border="1"> <tr> <td>1</td><td>2</td><td>3</td><td>4</td><td>5</td><td></td><td></td><td></td><td></td><td></td> </tr> <tr> <td>Brown</td><td>White</td><td>Blue</td><td>Black</td><td>Grey</td><td></td><td></td><td></td><td></td><td></td> </tr> </table>								1	2	3	4	5						Brown	White	Blue	Black	Grey					
1	2	3	4	5																														
Brown	White	Blue	Black	Grey																														
CN3	CA/LTW0808BF01	M8 A-Code 8 pin Female	UL20549 or UL2517 AWG#26	Black PUR or PVC Jacket	IP67	1 m	<table border="1"> <tr> <td>1</td><td>2</td><td>3</td><td>4</td><td>5</td><td>6</td><td>7</td><td>8</td><td></td><td></td> </tr> <tr> <td>White</td><td>Brown</td><td>Green</td><td>Yellow</td><td>Grey</td><td>Pink</td><td>Blue</td><td>Red</td><td></td><td></td> </tr> </table>								1	2	3	4	5	6	7	8			White	Brown	Green	Yellow	Grey	Pink	Blue	Red		
1	2	3	4	5	6	7	8																											
White	Brown	Green	Yellow	Grey	Pink	Blue	Red																											
CN4	CA/LTW1208BM01	M12 A-Code 8 pin Male	UL2517 AWG#24	Black PVC Jacket	IP68	1 m	<table border="1"> <tr> <td>1</td><td>2</td><td>3</td><td>4</td><td>5</td><td>6</td><td>7</td><td>8</td><td></td><td></td> </tr> <tr> <td>White</td><td>Brown</td><td>Green</td><td>Yellow</td><td>Grey</td><td>Pink</td><td>Blue</td><td>Red</td><td></td><td></td> </tr> </table>								1	2	3	4	5	6	7	8			White	Brown	Green	Yellow	Grey	Pink	Blue	Red		
1	2	3	4	5	6	7	8																											
White	Brown	Green	Yellow	Grey	Pink	Blue	Red																											
CN5A CN5B	CA/LTW1204BMD01	M12 D-Code 4 pin Male Shielded	UL2517 AWG#22	Black PVC Jacket	IP68	1 m	<table border="1"> <tr> <td>1</td><td>2</td><td>3</td><td>4</td><td></td><td></td><td></td><td></td><td></td><td></td> </tr> <tr> <td>Brown</td><td>White</td><td>Blue</td><td>Black</td><td></td><td></td><td></td><td></td><td></td><td></td> </tr> </table>								1	2	3	4							Brown	White	Blue	Black						
1	2	3	4																															
Brown	White	Blue	Black																															

## Verify the installation

- Check all connection: power supply and inputs/outputs.
- Make sure all settings right for the application.
- Make sure the power supply is suitable for the drive.
- If possible, remove the load from the motor shaft to avoid that wrong movements cause damage.
- Enable the current to the motor and verify the applied torque.
- Enable a movement of some steps and verify if the rotation direction is the desired one.
- Disconnect the power supply, connect the load on the motor and check the full functionality.

## Analysis of malfunctions



*When any of the following situations occur, the drive is placed in a fault condition.*

DEFECT	CAUSE	ACTION
Intervention of the thermal protection.	Can be caused by a heavy working cycle or a high current in the motor.	Improve the drive cooling by a natural or fan air flow. Consider to use a motor with a higher torque vs current rating.
Intervention of the current protection.	Short circuit on the motor powering stage(s) of the drive.	Check motor windings and cables to remove the short circuits replacing faulty cables or motor if necessary.
Intervention of the over/under voltage protection	Supply voltage out of range.	Check the value for the supply voltage.
Open phase motor protection.	Motor windings to drive not proper connection.	Check motor cables and connections to the drive.



*When any of the following situations occur, the drive doesn't work and isn't placed in an error condition.*

DEFECT	CAUSE	ACTION
Noisy motor movement with vibrations.	Can be caused by a lack of power supply to a phase of the motor or a poor regulation of the winding currents.	Check the cables and connections of the motor and/or change the motor speed to avoid a resonance region.
The external fuse on the power supply of the drive is burned.	Can be caused by a wrong connection of the power supply.	Connect the power supply correctly and replace the fuse.
At high speed, the motor torque is not enough.	Can be due to a 'self-limitation' of motor current and torque.	Increase the motor current (always within the limits), increase the supply voltage, change motor connection from series to parallel.

**Ever Motion solutions**

Via del Commercio, 2/4 - 9/11

Loc. San Grato Z. I

26900 - L O D I - Italy

Phone +39 0371 412318 - Fax +39 0371 412367

email: [infoever@everelettronica.it](mailto:infoever@everelettronica.it)

web: [www.everelettronica.it](http://www.everelettronica.it)

