

## SW1A4185H161-Controller bipolar drive for 2 phase step motor :

- AC power Supply: 17 ÷ 100Vac;
- Phase current : up to 8.5 A<sub>RMS</sub> (12.0 A<sub>PK</sub>);
- Chopper frequency : ultrasonic 33KHz;
- Step angle: from full step up to 1/128;
- Protections: over-current, over-temperature, short circuit phase-phase motor and phase-ground;
- digital inputs (opto-coupled);
- digital outputs (opto-coupled);
- analog inputs;
- Size and mass: 165 x 108,5 x 54,3 mm without connectors (L x D x H); weight : 760 gr ;
- IP protection: IP20;
- Working temperature 5°C ÷ 40°C ; Storage temperature -25°C ÷ 55°C ;
- Humidity : 5% ÷ 85% not condensing;

EtherCAT®

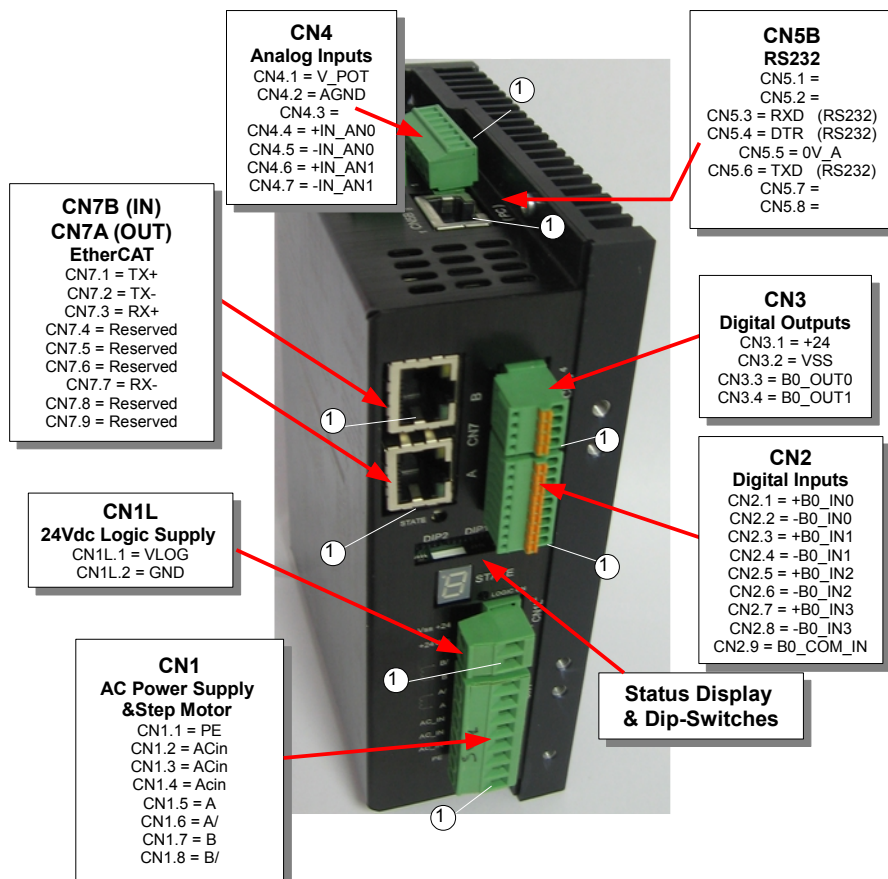

Refer to installation use and maintenance manual for more information.

Available user manual at link <http://www.everelettronica.it/manhw.html>.

CN1 : Power Supply & Motor			
8 position, pitch 5.08mm., PCB header connector			
Pos	Name	Characteristics	
1	PE	EARTH Input	Environmental earthing
2	AC <sub>IN</sub>	PWR Input	AC input power supply Motor.
3	AC <sub>IN</sub>	PWR Input	AC input power supply Motor
4	AC <sub>IN</sub>	PWR Input	AC input power supply Motor
5	A	PWR Output	Phase A motor
6	A/	PWR Output	Phase A/ motor
7	B	PWR Output	Phase B motor
8	B/	PWR Output	Phase B/ motor

CN1L : 24VDC Logic Supply (required)			
2 position, pitch 5.08mm., PCB header connector			
Pos	Name	Characteristics	
1	VLOG	PWR Input	Positive power supply Logics
2	GND	PWR Input	Negative power supply Logics

CN2 : Digital Inputs			
9 position, pitch 2.5mm., PCB header connector			
Pos	Name	Characteristics	
1	+B0_IN0	Digital Input	Positive terminal digital input B0_IN0
2	-B0_IN0	Digital Input	Negative terminal digital input B0_IN0
3	+B0_IN1	Digital Input	Positive terminal digital input B0_IN1
4	-B0_IN1	Digital Input	Negative terminal digital input B0_IN1
5	+B0_IN2	Digital Input	Positive terminal digital input B0_IN2
6	-B0_IN2	Digital Input	Negative terminal digital input B0_IN2
7	+B0_IN3	Digital Input	Positive terminal digital input B0_IN3
8	-B0_IN3	Digital Input	Negative terminal digital input B0_IN3
9	B0_COM_IN	PWR Input	Reference common inputs (for use at single-ended)

CN3 : Digital Outputs			
4 position, pitch 2.5mm., PCB header connector			
Pos	Name	Characteristics	
1	+24V	PWR Input	Positive power supply digital outputs.
2	VSS	PWR Input	Negative reference power supply digital outputs.
3	B0_OUT0	Digital Output	Open Emitter Output (Source Current) B0_OUT0
4	B0_OUT1	Digital Output	Open Emitter Output (Source Current) B0_OUT1

CN4 : Analog Inputs			
7 position, pitch 3.81mm., PCB header connector			
Pos	Name	Characteristics	
1	V_POT	PWR Output	Positive power supply output for potentiometers.
2	AGND	PWR Output	Negative reference output for potentiometers.
3	n.c.		Not connected
4	+IN_AN0	Analog Input	Positive terminal analog input IN_AN_0
5	-IN_AN0	Analog Input	Negative terminal analog input IN_AN_0
6	+IN_AN1	Analog Input	Positive terminal analog input IN_AN_1
7	-IN_AN1	Analog Input	Negative terminal analog input IN_AN_1

CN5B: RS232			
RJ45 , 8 position, PCB shielded header connector			
Pos	Name	Characteristics	
1	n.c.		Not connected
2	n.c.		Not connected
3	RXD	Digital Input	Input RS232 receiver
4	DTR	Digital Output	Output Data Transmit Ready RS232
5	0V_A	PWR Output	Reference (ground) communication interface.
6	TXD	Digital Output	Output transmitter RS232
7	n.c.		Not connected
8	n.c.		Not connected

CN7A (OUT) = CN7B (IN) : EtherCAT			
RJ45 , 8 positions, PCB fully shielded header connector			
Pos	Name	Characteristics	
1	TX+	Digital Output	Positive Transmission Data
2	TX-	Digital Output	Negative Transmission Data
3	RX+	Digital Input	Positive Receive Data
4	Reserved		Reserved
5	Reserved		Reserved
6	RX-	Digital Input	Negative Receive Data
7	Reserved		Reserved
8	Reserved		Reserved

Nota: Pin numbering is done according with TIA/EIA-568

Attention: the jumper **JMP600** must not be closed in position 1 and 2 or in position 3 and 4 at the same time.

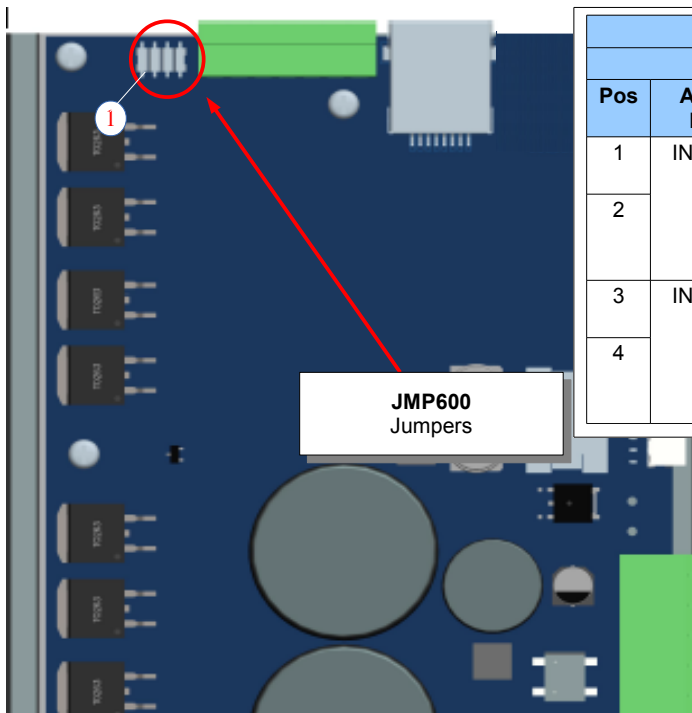

JMP600: analog inputs setting						
4 position, pitch 2.54mm., PCB header						
Pos	Analog Input	Characteristics		Factory Setting	Connections	
1	IN_AN_0	Differential ±10V	Jumper inserted		+IN_AN0	CN4.4
					-IN_AN0	CN4.5
2		Potentiometer	Jumper inserted	■	V_POT	CN4.1
					AGND	CN4.2
3	IN_AN_1	Differential ±10V	Jumper inserted		+IN_AN1	CN4.6
					-IN_AN1	CN4.7
4		Potentiometer	Jumper inserted	■	V_POT	CN4.1
					AGND	CN4.2
					+IN_AN1	CN4.6

## Dip-switches & Display

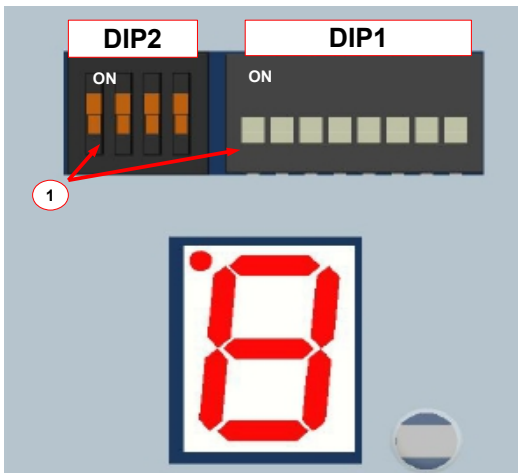

The functionality of the Dip-Switches depends on the Firmware installed on the drive (Refer to the Software Manual) .

At the moment of delivery, the default configuration of the drive is as follows:  
 DIP1.5=ON    DIP1.8 = ON other contacts DIP1 = OFF  
 DIP2 = all OFF

Operational statuses and their signals	
	Missing Operating System: no software application stored on drive
	Firmware update: Updating of new software in progress.
	Initialization: the drive executes the start-up procedure (a few seconds after the start-up procedure has begun).
	Correct functioning
	Voltage of the DC bus near the maximal value
	Drive temperature is near to the maximum value
	Enable OFF, current zero
	Error: expired eePLC software trial
	Security intervention of watchdog;
	Internal Software Error;
	Missing calibration values;
	Error: eePLC application error
	Error: Feature Unavailable
	Open motor phases
	over/under voltage (1);
	over current on the motor output;
	over temperature of the drive;

Refer to software manual for more information and details.  
 Available user manual at link <http://www.evereletronica.it/mansw.html>.

# Digital inputs connection

## Differential Connection

### 2 - 5V INPUT

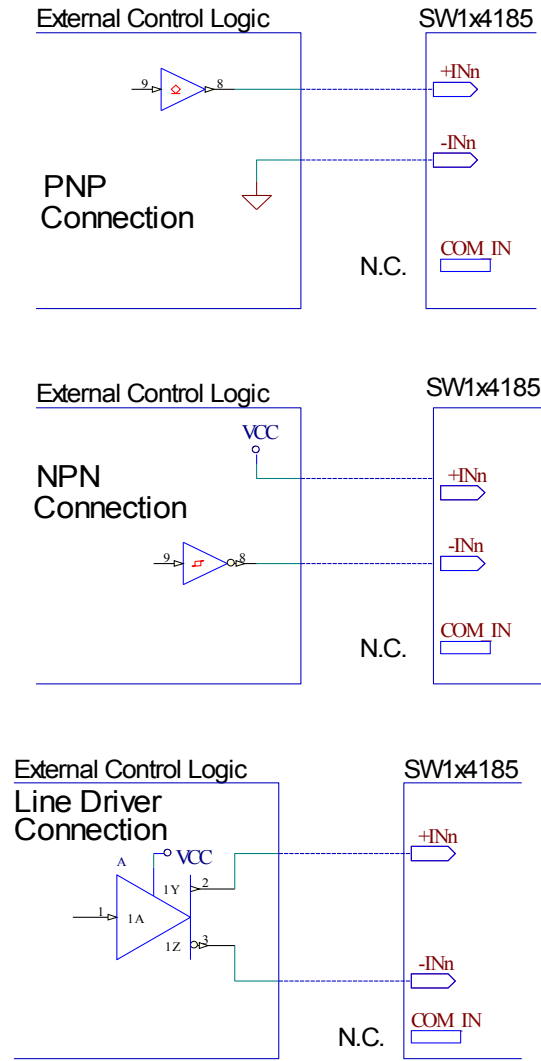

## Single-ended Connection

### 11-24V INPUTS

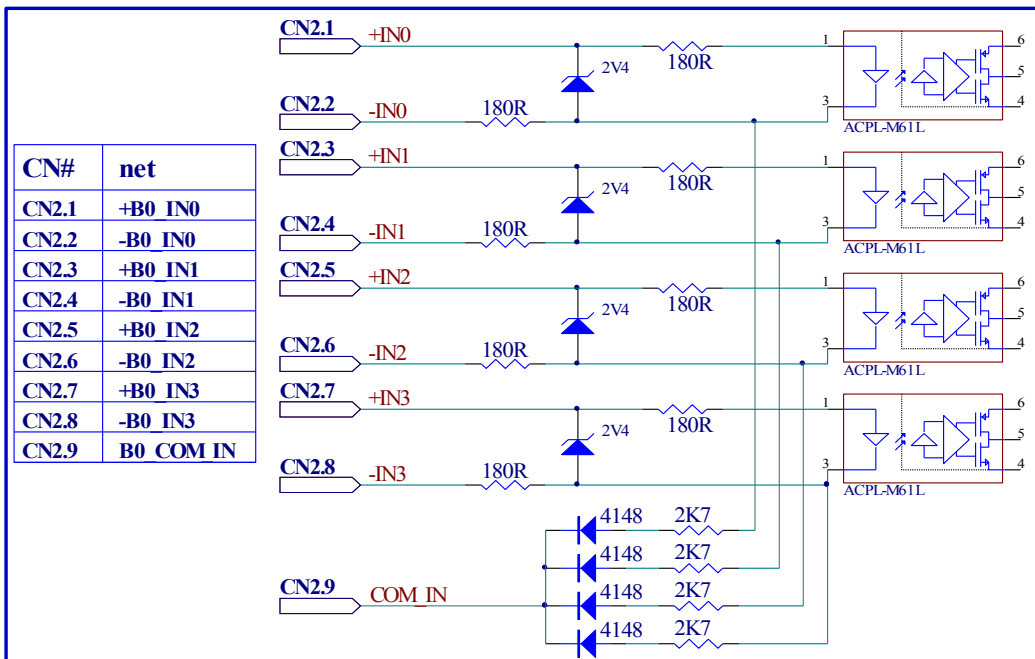
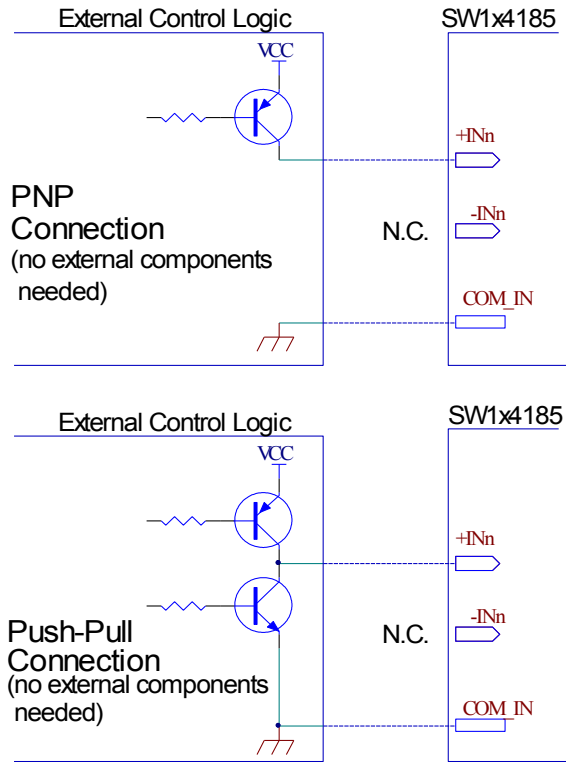

## Digital output connection

Digital outputs  $V_{OUTmax}=24Vdc$ ,  $I_{OUTmax}=100mA$

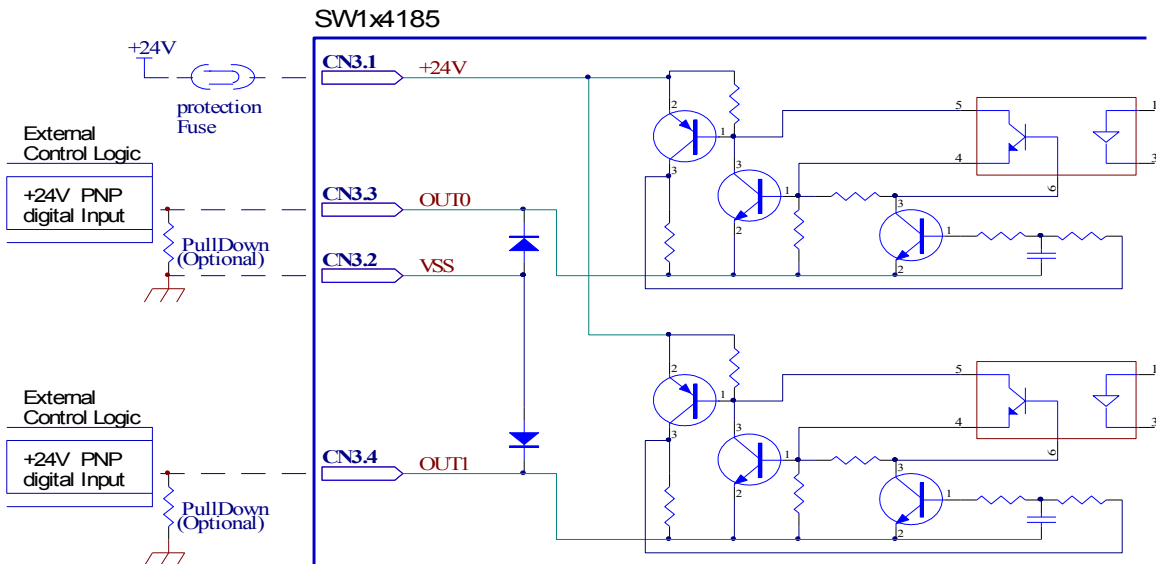

## Analog input connection

Analog input  $\pm 10Vdc$  CEI EN 61131-2 type, not isolated.

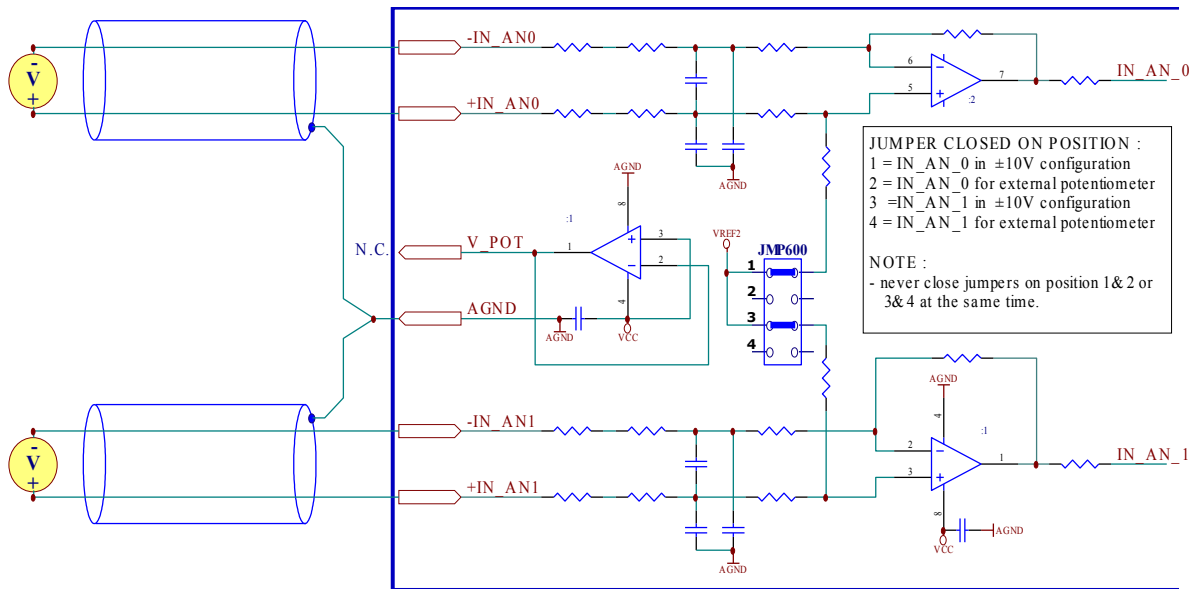

Analog input for potentiometer connection.

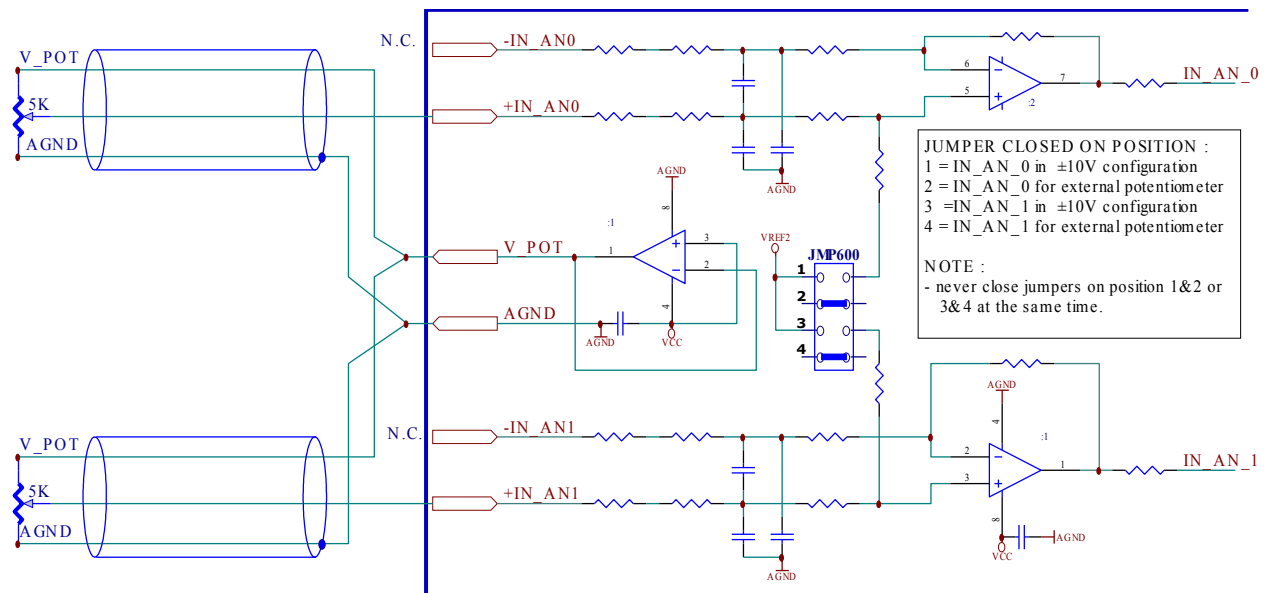

## Mating cable kit

<b>CN1</b>	8 position, pitch 5.08mm., plug connector	PHOENIX CONTACT p# <b>MSTB 2,5/8-ST-5,08</b>	order cod. <b>1757077</b>
<b>CN1L</b>	2 position, pitch 5.08mm., plug connector	PHOENIX CONTACT p# <b>MSTB 2,5/2-ST-5,08</b>	order cod. <b>1757019</b>
<b>CN2</b>	9 position, pitch 2.5mm., plug connector	PHOENIX CONTACT p# <b>FK MC0,5/9-ST-2,5</b>	order cod. <b>1881396</b>
<b>CN3</b>	4 position, pitch 2.5mm., plug connector	PHOENIX CONTACT p# <b>FK MC0,5/4-ST-2,5</b>	order cod. <b>1881341</b>
<b>CN4</b>	7 position, pitch 3.81mm., plug connector	PHOENIX CONTACT p# <b>MC1,5/7-ST-3,81</b>	order cod. <b>1803620</b>
<b>CN5B</b>	RJ45 ,8 position, plug connector	MOLEX p# <b>FCC 68 compliants and equivalents</b>	order cod. <b>44915-0011</b>
<b>CN6</b>	5 position, pitch 3.81mm., plug connector	PHOENIX CONTACT p# <b>MC1,5/5-ST-3,81</b>	order cod. <b>1881354</b>
<b>CN7A/B</b>	RJ45 ,8 position, plug connector	MOLEX p# <b>FCC 68 compliants and equivalents</b>	order cod. <b>44915-0011</b>

## Section of the cables

<b>Power supply</b>	Min 0.5mm <sup>2</sup> (AWG20)		<b>Communication interface</b>	Follow the respective standard
<b>Logic supply</b>	Max 2.5mm <sup>2</sup> (AWG12)		<b>Digital input</b>	Min 0.14mm <sup>2</sup> (AWG25)
<b>Motor output</b>	Min 0.5mm <sup>2</sup> (AWG20)		<b>Digital output</b>	Max 0.5mm <sup>2</sup> (AWG20)
	Max 2.5mm <sup>2</sup> (AWG12)		<b>Analog inputs</b>	Max 1.5mm <sup>2</sup> (AWG16)

## Verify the installation

- Check all connection : power supply and inputs/outputs.
- Make sure all settings right for the application.
- Make sure the power supply is suitable for the drive.
- If possible, remove the load from the motor shaft to avoid that wrong movements cause damage.
- Enable the current to the motor and verify the applied torque.
- Enable a movement of some steps and verify if the rotation direction is the desired one.
- Disconnect the power supply, connect the load on the motor and check the full functionality.

## Check the detected fail function

 When one of the following situations occur, the drive doesn't function correctly and it is reported an error.

DEFECT	CAUSE	ACTION
The external fuse to the drive burns	May be due to a wrong connection of the power supply.	Adjust the connection and recover the fuse. Use a fuse suitable for the application.
Over temperature protection.	May be due to a duty cycle	Increase the air flux and if it is possible chose a motor with higher torque at same current value.
Over current protection.	May be due to a short circuit on the motor power stage.	Shut down the power supply and check if the motor is damaged
Noisy motor movement with vibrations.	May be caused due to a state of resonance.	Increase the resolution of the step angle and/or change the motor velocity to avoid resonance area
The motor produce torque but doesn't rotate	May be caused due to a wrong connection of the I/O's.	Check the connection of the I/O's