

Installation instructions

i Refer to installation use and maintenance manual for more information.
Available user manual at link <http://www.everelettronica.it/manhw.html>



Bipolar drive for 2 phase step motor

- DC power Supply: 24 ± 40 Vdc;
- Phase current: up to 4.2 ARMS (6.0 A_{PK});
- Chopper frequency: ultrasonic 33KHz;
- Step angle: from full step up to 1/128;
- Protections: over-current, over-temperature, short circuit phase-phase motor and phase-ground;
- Digital inputs (opto-coupled);
- Digital outputs (opto-coupled);
- Size and mass: 142 x 74 x 37 mm without connectors (L x D x H: refer to picture); weight : 500 gr;
- IP protection: IP20;
- Working temperature 5°C ± 40°C; Storage temperature -25°C ± 55°C;
- Humidity : 5% ± 85% not condensing;

Mechanical data

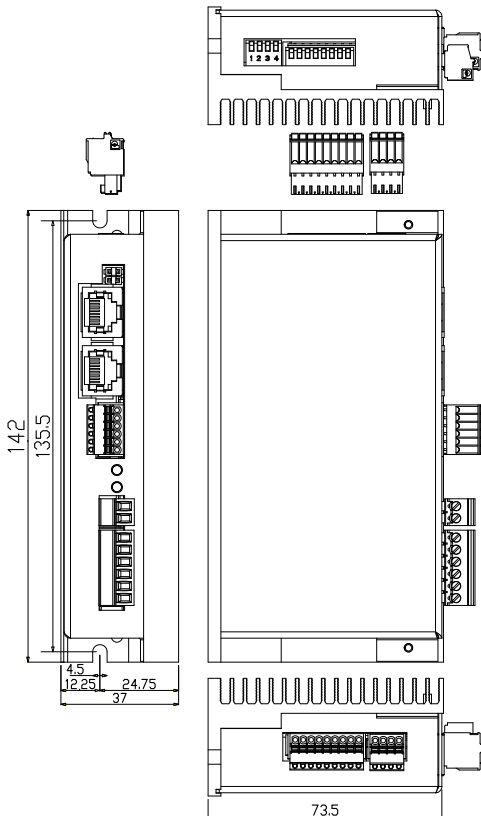

System connections, jumpers and dip switches position

Connectors:



Modbus or CANbus

FAULT led

POWER ON led

CN1A Logic supply

CN1A.1	GND
CN1A.2	VLOG

CN1 Power supply and stepper motor

CN1.1	GND
CN1.2	V+/
CN1.3	A
CN1.4	A/
CN1.5	B
CN1.6	B/

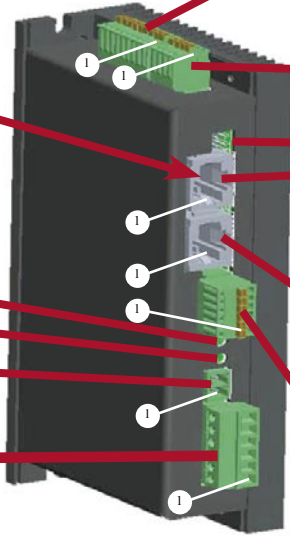

CN2 Digital inputs Hi-Freq	
CN2.1	+B0_IN0
CN2.2	-B0_IN0
CN2.3	+B0_IN1
CN2.4	-B0_IN1
CN2.5	+B0_IN2
CN2.6	-B0_IN2
CN2.7	+B0_IN3
CN2.8	-B0_IN3
CN2.9	B0_COM_IN

CN3 Digital outputs Hi-Freq	
CN3.1	+24
CN3.2	VSS
CN3.3	B0_OUT0
CN3.4	B0_OUT1

CN5B Digital inputs Hi-Freq		
	CANbus version	RS232/485 version
CN5B.1	CAN_H	+RX (RS485)
CN5B.2	CAN_L	-RX (RS485)
CN5B.3	CAN_GND	RXD (RS232)
CN5B.4		DTR (RS232)
CN5B.5		0V_A
CN5B.6		TXD (RS232)
CN5B.7	CAN_GND_0	+TX (RS485)
CN5B.8		-TX (RS485)

CN5A Digital inputs Hi-Freq		
	CANbus version	RS232/485 version
CN5A.1	CAN_H	+RX (RS485)
CN5A.2	CAN_L	-RX (RS485)
CN5A.3	CAN_GND	
CN5A.4		
CN5A.5		0V_A
CN5A.6		
CN5A.7	CAN_GND_0	+TX (RS485)
CN5A.8		-TX (RS485)

CN4 Analog inputs	
CN4.1	V_POT
CN4.2	AGND
CN4.3	+IN_AN0
CN4.4	-IN_AN0
CN4.5	+IN_AN1
CN4.6	-IN_AN1

Jumpers:



Attention: the jumper JMP600 must not be closed in position 1 and 2 or in position 3 and 4 at the same time.
Attention: the jumper JMP700 with a RS485 Half-Duplex connection, insert only 1 jumper indifferently in position 1 or 2.

Rear Side

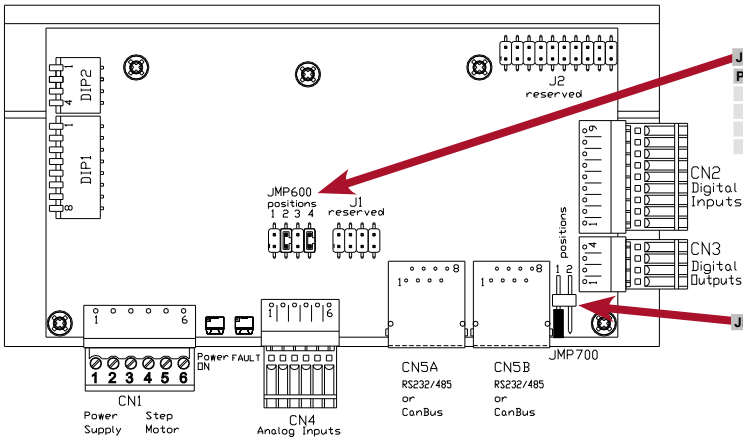

JMP600 jumpers	
Position	Function
1	IN_AN0 differential ±10V
2	IN_AN0 potentiometer
3	IN_AN1 differential ±10V
4	IN_AN1 potentiometer

JMP700 jumper

Front Side

System connection and jumpers functions

CN1: Power supply and Motor

6 positions, pitch 3.81mm, PCB header connector

Pos	Name	Characteristics	
1	GND	PWR input	Negative power supply
2	V+	PWR input	Positive power supply
3	A	PWR output	Motor phase A
4	A/	PWR output	Motor phase A/
5	B	PWR output	Motor phase B
6	B/	PWR output	Motor phase B/

CN1A: Logic supply

2 positions, pitch 3.81mm, PCB header connector

Pos	Name	Characteristics	
1	GND	PWR input	Negative logic supply
2	VLOG	PWR input	Positive logic supply

CN2: Digital inputs Hi-Freq

9 positions, pitch 2.5mm, PCB header connector

Pos	Name	Characteristics	
1	+B0_IN0	Digital input	Positive terminal digital input B0_IN0
2	-B0_IN0	Digital input	Negative terminal digital input B0_IN0
3	+B0_IN1	Digital input	Positive terminal digital input B0_IN1
4	-B0_IN1	Digital input	Negative terminal digital input B0_IN1
5	+B0_IN2	Digital input	Positive terminal digital input B0_IN2
6	-B0_IN2	Digital input	Negative terminal digital input B0_IN2
7	+B0_IN3	Digital input	Positive terminal digital input B0_IN3
8	-B0_IN3	Digital input	Negative terminal digital input B0_IN3
9	B0_COM_IN	Digital input	Reference common inputs (for use of 24VDC)

CN3: Digital outputs Hi-Freq

4 positions, pitch 2.5mm, PCB header connector

Pos	Name	Characteristics	
1	+24	PWR input	Positive power supply digital outputs
2	VSS	PWR input	Negative reference power supply digital outputs
3	B0_OUT0	Digital output	Output open emitter (Source Current) B0_OUT0
4	B0_OUT1	Digital output	Output open emitter (Source Current) B0_OUT1

CN4: Analog inputs

6 positions, pitch 2.5mm, PCB header connector

Pos	Name	Characteristics	
1	V_POT	PWR output	Output positive power supply for potentiometers
2	AGND	PWR output	Output negative references for potentiometers
3	+IN_AN0	Analog input	Positive terminal analog input IN_AN0
4	-IN_AN0	Analog input	Negative terminal analog input IN_AN0
5	+IN_AN1	Analog input	Positive terminal analog input IN_AN1
6	-IN_AN1	Analog input	Negative terminal analog input IN_AN1

CN5A - CN5B: RS232/RS485 versions

RJ45, 8 positions, PCB shielded header connector

Pos	CN5A (IN) RS485	CN5B (OUT) RS485 RS242	Characteristics	
1	+RX	+RX	Digital input	Non-inverting input RS485 receiver
2	-RX	-RX	Digital input	Inverting input RS485 receiver
3	n.c.	RXD	Digital input	Input RS232 receiver
4	n.c.	DTR	Digital output	Output data transmit ready RS232
5	0V_A	0V_A	PWR output	Reference (mass) communication interface
6	n.c.	TXD	Digital output	Output RS232 transmitter
7	+TX	+TX	Digital output	Non-inverting output RS485 transmitter
8	-TX	-TX	Digital output	Inverting output RS485 transmitter

CN5A - CN5B: CANbus version

RJ45, 8 positions, PCB shielded header connector

Pos	Name	Characteristics		
1	CAN_H	Digital I/O	Bus line dominant HIGH	
2	CAN_L	Digital I/O	Bus line dominant LOW	
3	CAN_GND	PWR output	Signal ground	
4	n.c.		Not connected	
5	n.c.		Not connected	
6	n.c.		Not connected	
7	CAN_GND_O	PWR output	Optional signal ground	
8	n.c.		Not connected	

JMP600: Analog inputs settings

4 positions, pitch 2.54 mm, PCB header

Pos	Analog input	Characteristics		Default
1	IN_AN0	Differential	Jumper inserted	
2		Potentiometer	Jumper inserted	■
3	IN_AN1	Differential	Jumper inserted	
4		Potentiometer	Jumper inserted	■

JMP700: Insertion of termination resistors on communication interfaces

2 positions, pitch 2.54 mm, PCB header

Pos	Factory setting	RS232/485	CANbus versions
1	Jumper <u>not</u> inserted	120 ohm resistance on transmission line RS485 not inserted	Not connected
	■ Jumper inserted	120 ohm resistance on transmission line RS485 inserted	Not connected
2	Jumper <u>not</u> inserted	120 ohm resistance on transmission line RS485 not inserted	120 ohm resistance on CANbus not inserted
	■ Jumper inserted	120 ohm resistance on transmission line RS485 inserted	120 ohm resistance on CANbus inserted

Dip-Switches settings

Dip-switch allocation											
DIP2				DIP1							
U1	U0	ID6	ID5	ID4	ID3	ID2	ID1	ID0	BD2	BD1	BD0
1			4	1							9

Drive's baud rate selection				
BD2	BD1	BD0	Modbus rate	CANopen rate
OFF	OFF	OFF	115200	1 M
OFF	OFF	ON	57600	500 K
OFF	ON	OFF	38400	250 K
OFF	ON	ON	19200	125 K
ON	OFF	OFF	9600	100 K
ON	OFF	ON	4800	50 K
ON	ON	OFF	2400	50 K
ON	ON	ON	1200	50 K

Drive's ID number selection							
ID6	ID5	ID4	ID3	ID2	ID1	ID0	Node ID #
OFF	OFF	OFF	OFF	OFF	OFF	OFF	Not allowed
OFF	OFF	OFF	OFF	OFF	OFF	ON	1
OFF	OFF	OFF	OFF	OFF	ON	OFF	2
OFF	OFF	OFF	OFF	OFF	ON	ON	3
OFF	OFF	OFF	OFF	ON	OFF	OFF	4
OFF	OFF	OFF	OFF	ON	OFF	ON	5
OFF	OFF	OFF	OFF	ON	ON	OFF	6
OFF	OFF	OFF	OFF	ON	ON	ON	7
OFF	OFF	OFF	ON	OFF	OFF	OFF	8
OFF	OFF	OFF	ON	OFF	OFF	ON	9
OFF	OFF	OFF	ON	OFF	ON	OFF	10
OFF	OFF	OFF	ON	OFF	ON	ON	11
OFF	OFF	OFF	ON	ON	OFF	OFF	12
OFF	OFF	OFF	ON	ON	OFF	ON	13
OFF	OFF	OFF	ON	ON	ON	OFF	14
OFF	OFF	OFF	ON	ON	ON	ON	15
OFF	OFF	ON	OFF	OFF	OFF	OFF	16
OFF	OFF	ON	OFF	OFF	OFF	ON	17
OFF	OFF	ON	OFF	OFF	ON	OFF	18
OFF	OFF	ON	OFF	OFF	ON	ON	19
OFF	OFF	ON	OFF	ON	OFF	OFF	20
OFF	OFF	ON	OFF	ON	OFF	ON	21
OFF	OFF	ON	OFF	ON	ON	OFF	22
OFF	OFF	ON	OFF	ON	ON	ON	23
OFF	OFF	ON	ON	OFF	OFF	OFF	24
XX	XX	XX	XX	XX	XX	XX
ON	ON	ON	ON	ON	ON	ON	127

High-Freq digital input connection

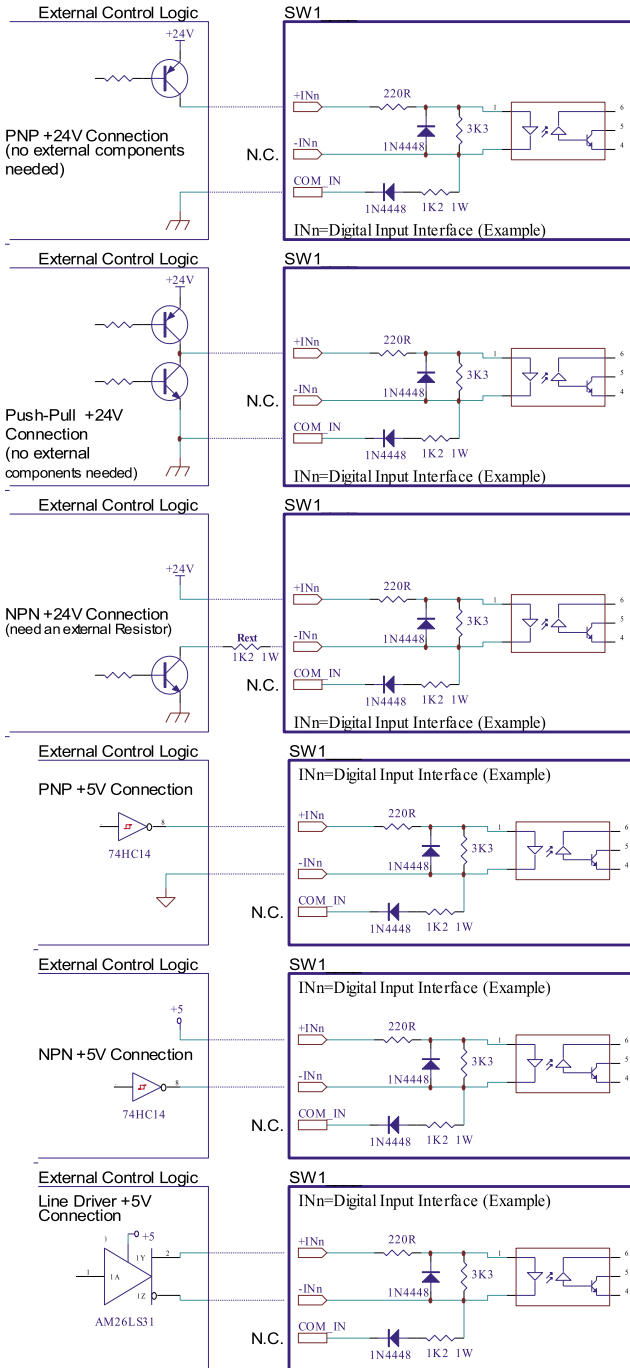

Analog input connection

Analog input for potentiometer connection

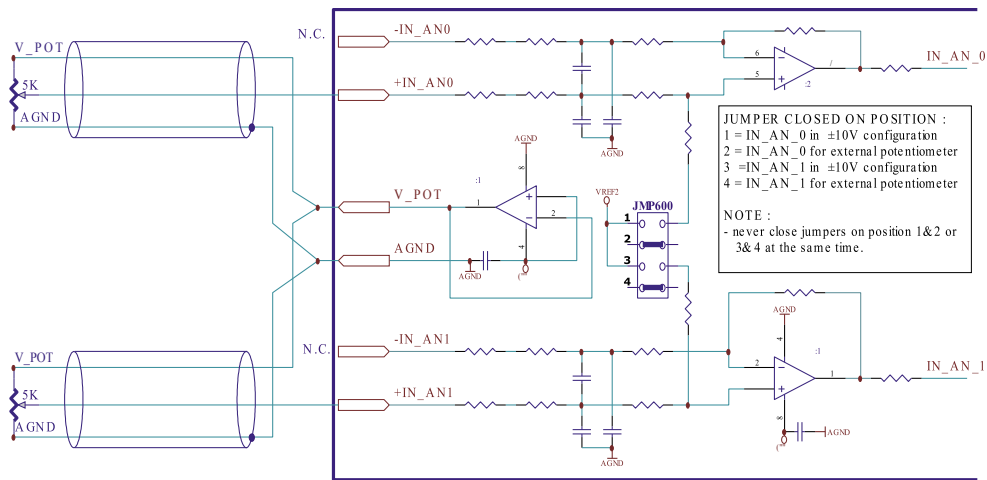

Analog output connection

Analog output 0-10Vdc optically isolated

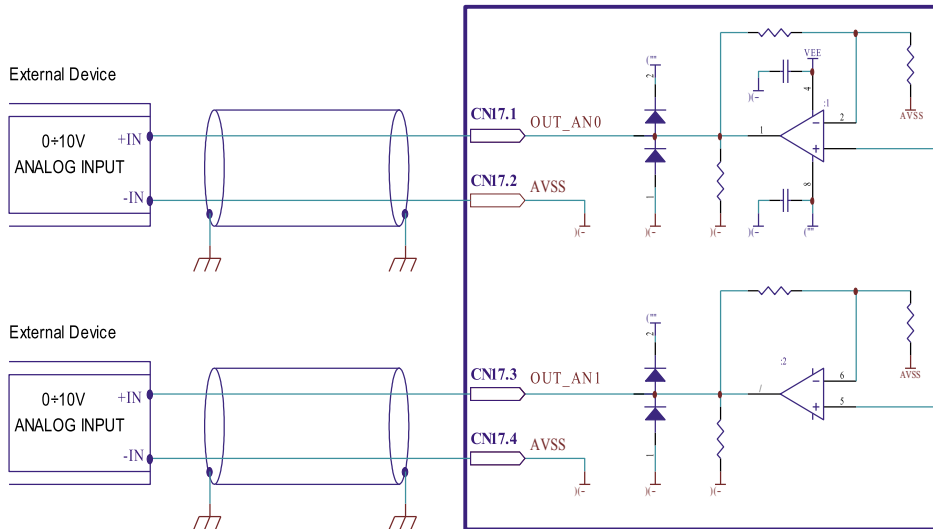

Operational statuses and signals

The working conditions of the drive SW1D2142 are displayed by means of the green FAULT LED light. The statuses which can be visualized are:

- Slow flashing (0.5 Hz) ==> NORMAL functioning ;
- Quick flashing (10Hz) ==> FAULT condition;
- Slow flashing (10Hz) alternating quick flashing (5 Hz) ==> WARNING condition

Mating cable kit

Connector	Description	Order code
CN1	6 position, pitch 3.81mm., plug connector PHOENIX CONTACT p# MC1,5/6-ST-3,81	1803617
CN1A	2 position, pitch 3.81mm., plug connector PHOENIX CONTACT p# MC1,5/2-ST-3,81	1803578
CN2	9 position, pitch 2.5mm., plug connector PHOENIX CONTACT p# FK MC0,5/9-ST-2,5	1881396
CN3	4 position, pitch 2.5mm., plug connector PHOENIX CONTACT p# FK MC0,5/4-ST-2,5	1881341
CN4	6 position, pitch 3.81mm, plug connector PHOENIX CONTACT p# FK MC0,5/6-ST-2,5	1801367
CN5A / B	8 position, RJ45, plug connector, MOLEX p# FCC 68 compliants and equivalents	44915-0011

Section of the cables

Function	Cable	
	Minimum	Maximum
Power supply	0.5 mm ² (AWG20)	1.5 mm ² (AWG15)
Motor output	0.5 mm ² (AWG20)	1.5 mm ² (AWG15)
Communication interface	0.25 mm ² (AWG23) CANbus CIA-CANopen	--
Analog inputs	0.14 mm ² (AWG25)	--
Digital inputs	0.14 mm ² (AWG25)	0.5 mm ² (AWG20)
Digital outputs	0.14 mm ² (AWG25)	0.5 mm ² (AWG20)

Verify the installation

- Check all connection : power supply and inputs/outputs.
- Make sure all settings right for the application.
- Make sure the power supply is suitable for the drive.
- If possible, remove the load from the motor shaft to avoid that wrong movements cause damage.
- Enable the current to the motor and verify the applied torque.
- Enable a movement of some steps and verify if the rotation direction is the desired one.
- Disconnect the power supply, connect the load on the motor and check the full functionality.

Analysis of malfunctions



When one of the following situations occur, the drive doesn't function correctly and it is reported an error.

DEFECT	CAUSE	ACTION
The external fuse to the drive burns.	May be due to a wrong connection of the power supply.	Adjust the connection and recover the fuse. Use a fuse suitable for the application.
Over temperature protection.	May be due to a duty cycle.	Increase the air flux and if it is possible chose a motor with higher torque at same current value.
Over current protection.	May be due to a short circuit on the motor power stage.	Shut down the power supply and check if the motor is damaged.
Noisy motor movement with vibrations.	May be caused due to a state of resonance.	Increase the resolution of the step angle and/or change the motor velocity to avoid r esonance area.
The motor produce torque but doesn't rotate.	May be caused due to a wrong connection of the I/O's.	Check the connection of the I/O's.

EVER Elettronica

Via del Commercio, 2/4 - 9/11

Loc. San Grato Z. I

26900 - L O D I - Italy

Phone +39 0371 412318 - Fax +39 0371 412367

email: infoever@everelettronica.it

web: www.everelettronica.it

